

Quality Parts

GRUPPO 1000 AT

68

1000 AT FAMILY

RICAMBI ALTERNATIVI PER

MOTORI SAME SLH

NON ORIGINAL PARTS FOR

SAME SLH ENGINES

REL 905

Questo catalogo contiene dati ed informazioni provenienti dalla pluriennale esperienza di Finimpianti. Tuttavia non possiamo assumere alcuna responsabilità per eventuali dati errati od incompleti.

Tutti i dati e le informazioni contenute nel presente catalogo sono fornite a puro scopo informativo e senza responsabilità e non potranno dare adito ad alcuna forma di risarcimento.

Visto il continuo sviluppo dei nostri prodotti, Finimpianti si riserva il diritto di apportare modifiche senza preavviso.

Denominazioni, numeri e codici originali sono riportati a puro titolo di riferimento.

All the information and data contained in this catalogue came from the long Finimpianti experience. Nevertheless we can not assume any responsibility for possible mistakes.

All the information and data contained in this catalogue are provide "as is" without any representation or warranty express or implied. Under no circumstances whatsoever shall Finimpianti be liable for any damages whatsoever arising out of the use of the information and data contained in this catalogue.

Finimpianti does not warrant the accuracy or completeness of the materials and content contained in this catalogue and reserves the right to correct any errors or omissions at any time without notice and without obligation to the users of this catalogue.

OEM names, codes and part numbers, used in this catalogue, are for reference only.

**GRUPPO 1000 AT
SAME
1000 AT FAMILY**

1	1000.3 AT	7786 ←
3	1000.3 AT	7787 → 8712
5	1000.3 AT	8713 →
7	1000.3 AT-POT	7786 ←
9	1000.3 AT-POT	7787 → 8712
11	1000.3 AT-POT	8713 →
13	1000.4 AT	18772 ←
15	1000.4 AT	18773 → 21296
17	1000.4 AT	21297 →
19	1000.4 AT1	1664 ←
21	1000.4 AT1	1665 → 5645
23	1000.4 AT2	4974 ←
25	1000.4 AT2	4975 →
27	1000.4 ATG	18772 ←
29	1000.4 ATG	18773 → 21296
31	1000.4 ATG	21297 →
33	1000.6 AT	4772 ←
35	1000.6 AT	4773 → 4847
37	1000.6 AT	4848 →

Questo catalogo contiene dati ed informazioni provenienti dalla pluriennale esperienza di Finimpianti. Tuttavia non possiamo assumere alcuna responsabilità per eventuali dati errati od incompleti.

Tutti i dati e le informazioni contenute nel presente catalogo sono fornite a puro scopo informativo e senza responsabilità e non potranno dare adito ad alcuna forma di risarcimento.

Visto il continuo sviluppo dei nostri prodotti, Finimpianti si riserva il diritto di apportare modifiche senza preavviso.

Denominazioni, numeri e codici originali sono riportati a puro titolo di riferimento.

All the information and data contained in this catalogue came from the long Finimpianti experience. Nevertheless we can not assume any responsibility for possible mistakes.





All the information and data contained in this catalogue are provide "as is" without any representation or warranty express or implied. Under no circumstances whatsoever shall Finimpianti be liable for any damages whatsoever arising out of the use of the information and data contained in this catalogue.





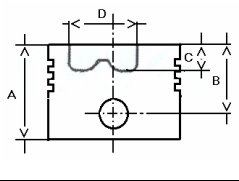

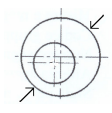
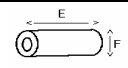

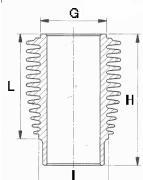
Finimpianti does not warrant the accuracy or completeness of the materials and content contained in this catalogue and reserves the right to correct any errors or omissions at any time without notice and without obligation to the users of this catalogue.

OEM names, codes and part numbers, used in this catalogue, are for reference only.

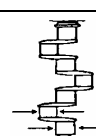
SAME

1000.3 AT	Cm³	CILINDRI CYLINDERS	ALESAGGIO BORE	CORSA STROKE	VERSIONE VERSION
	3000	3	105	115,5	7786 ←

		TESTA HEAD	H22		6	3	TIPO TYPE	A	
					4	2,5			
	FIN419PN 0.078.1236.0/10		E 86 F 35		23	4		G	115,5
					105	0.338.0060.6/20		FIN2404PC00	0.338.0052.6/10
								I	113
								L	125,5
							0.007.0762.0/40 ≡ 0.007.0762.0/50	FIN1991SL00	

		Nr.						ADATTABILE A: SUITABLE FOR:	
---	---	------------	---	---	---	---	---	--------------------------------	---

CR	RP	3	63,50	67,22	29,00		STD - 025 - 050 075 - 100	0.065.1225.0 + 0.065.1225.0	FIN478CR STD
----	----	---	-------	-------	-------	--	------------------------------	--------------------------------	--------------

MB	RP	4	70,00	74,02	26,25		STD - 025 - 050 075 - 100	0.065.1215.0 + 0.065.1216.0	FIN279MB STD
----	----	---	-------	-------	-------	--	------------------------------	--------------------------------	--------------





--	--	--	--	--	--	--	--	--	--



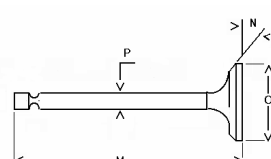

--	--	--	--	--	--	--	--	--	--

PB	BM	3	35,00	39,02	34,65		SEMIF.	2.1559.114.0/10	FIN110PB
----	----	---	-------	-------	-------	--	--------	-----------------	----------

TWS	AL	2	82,25	100,00	2,36		STD - 010 - 020	0.065.1218.0 + 0.065.1218.0	FIN167TWS STD
-----	----	---	-------	--------	------	--	-----------------	--------------------------------	---------------

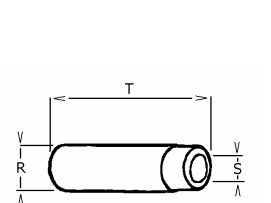
--	--	--	--	--	--	--	--	--	--

		Nr.	O	P	M	N		ADATTABILE A: SUITABLE FOR:									
								IN	FR	3	44	9	131	30°	A1	0.010.6017.0	FINA6041
								EX	FSN	3	39,5	9	130,5	45°	A1	0.010.6022.0	FINS6042

		Nr.	R	S	T		ADATTABILE A: SUITABLE FOR:								
							IN	G	3	15,03	9,02	60	I	0.007.1779.0/10	FIN6519ASA
							IN								
							EX	G	3	15,03	9,02	60	I	0.007.1779.0/10	FIN6519ASA
EX															

Ricambi non originali per motori. Denominazioni e codici originali, sono riportati a puro titolo di riferimento.





1 - 68





rel. 905



Non original engine parts. OEMs names and part numbers are for reference purpose only.







SAME







1000.3 AT	Cm³	CILINDRI CYLINDERS	ALESAGGIO BORE	CORSA STROKE	VERSIONE VERSION
	3000	3	105	115,5	7786 ←

		 0,5 mm	
0.351.0050.6/10		0.085.1450.0	0.085.0057.6
FIN7502CGA	FIN7502CGB	FIN6281HG	FIN3104SM

		 IN	 EX
0.007.0614.0/10	0.069.1450.0/30		
FIN5016CO	FIN3204CB		

Nr.	ENGINE KIT	
1		FIN1991SL00
1		FIN2404PC00
1		FIN3104SM
0.338.0065.6/20		FIN2051KIT

 LV	 LD					
2.1529.073.0	2.1529.141.0	0.87334.51.0	2.4239.100.0	0.010.3279.0	2.4419.340.0	2.4319.060.1
FIN2888RT	FIN2889RT	FIN8030AF	FIN8225PF	FIN8155NF	FIN8230OF	FIN8605FE

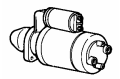
					 14V-35A	 14V-3KW ISKRA
2.4519.300.0		2.4619.030.1	2.4729.100.0	2.4619.010.2	2.9439.220.0/10	2.9619.180.0/10
FIN919FP		FIN1695E	FIN161NO	FIN1690DV	FIN2288VA	FIN201TL

1	Guarnizione testa 0,7 mm	Head Gaket 0,7 mm	0.085.1451.0	FIN6282HG
2	Guarnizione testa 0,8 mm	Head Gaket 0,8 mm	0.085.1453.0	FIN6283HG
3	Guarnizione testa 1,0 mm	Head Gaket 1,0 mm	0.085.1452.0	FIN6284HG
4	OR per canna (117,07X3,53)	Liner O ring (117,07X3,53)	2.1539.130.0/10	FIN1098OR
5	Pompa olio	Oil pump	0.010.5481.4	FIN046OP
6	Kit revisione pompa alimentazione	Fuel pump repairing kit	2.4519.269.0	FIN2919KFP
7	Filtro Aria 6"	Air cleaner 6"	2.4249.250.0/10	FIN8201AF
8	Filtro Aria 8"	Air cleaner 8"	0.87335.51.0	FIN8035AF
9	Filtro Aria (bagno olio)	Air cleaner (oil bath)	0.88329.50.3	FIN8205AF
10	Alternatore 26V-35A	Alternator 26V-35A-ISKRA	2.9439.260.0/10	FIN2305VA
11	Alternatore 14V-65A-ISKRA	Alternator 14V-65A-ISKRA	2.9439.420.0/10	FIN2320VA
12	Motorino d'avviamento 28V-3,2KW ISKRA	Starter engine 28V-3,2KW ISKRA	2.9619.120.0/10	FIN1865TL
13				
14				
15				

Ricambi non originali per motori. Denominazioni e codici originali, sono riportati a puro titolo di riferimento.





2 - 68





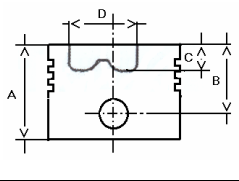

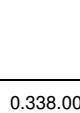
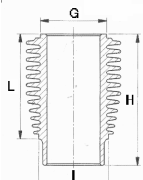
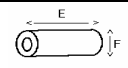

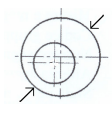
rel. 905

Non original engine parts. OEMs names and part numbers are for reference purpose only.

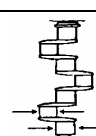
SAME

1000.3 AT	Cm³	CILINDRI CYLINDERS	ALESAGGIO BORE	CORSA STROKE	VERSIONE VERSION
	3000	3	105	115,5	7787 → 8712

		TESTA HEAD	H47		6	3	TIPO TYPE	A	
		A	97,25		4	2,5			
FIN419PN 0.078.1236.0/10		E	86		23	4		G	115,5
		F	35					H	194,5
	105	0.381.0060.6	FIN3102PC00	0.338.0052.6/10		FIN2320RS00		I	113
	105,5		FIN3102PC05	0.338.0053.6/10	FIN2320RS05		L	125,5	
	106					FIN2320RS10		0.007.0762.0/40 ≡ 0.007.0762.0/50	
						FIN1991SL00			

		Nr.						ADATTABILE A: SUITABLE FOR:	
---	---	------------	---	---	---	---	---	--------------------------------	---

CR	RP	3	63,50	67,22	29,00		STD - 025 - 050 075 - 100	0.065.1225.0 + 0.065.1225.0	FIN478CR STD
----	----	---	-------	-------	-------	--	------------------------------	--------------------------------	--------------

MB	RP	4	70,00	74,02	26,25		STD - 025 - 050 075 - 100	0.065.1215.0 + 0.065.1216.0	FIN279MB STD
----	----	---	-------	-------	-------	--	------------------------------	--------------------------------	--------------





--	--	--	--	--	--	--	--	--	--



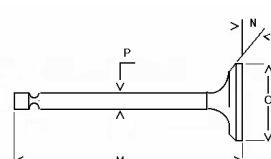

--	--	--	--	--	--	--	--	--	--

PB	BM	3	35,00	39,02	34,65		SEMIF.	2.1559.114.0/10	FIN110PB
----	----	---	-------	-------	-------	--	--------	-----------------	----------

TWS	AL	2	82,25	100,00	2,36		STD - 010 - 020	0.065.1218.0 + 0.065.1218.0	FIN167TWS STD
-----	----	---	-------	--------	------	--	-----------------	--------------------------------	---------------

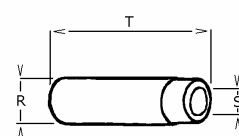
--	--	--	--	--	--	--	--	--	--

	IN EX		Nr.	O	P	M	N		ADATTABILE A: SUITABLE FOR:			
	IN		FR	3	44	9	131		30°	A1	0.010.6017.0	FINA6041
	EX		FSN	3	39,5	9	130,5		45°	A1	0.010.6022.0	FINS6042

	IN EX		Nr.	R	S	T		ADATTABILE A: SUITABLE FOR:			
	IN		G	3	15,03	9,02		60	I	0.007.1779.0/10	FIN6519ASA
	IN										
	EX		G	3	15,03	9,02		60	I	0.007.1779.0/10	FIN6519ASA
EX											

Ricambi non originali per motori. Denominazioni e codici originali, sono riportati a puro titolo di riferimento.





3 - 68





rel. 905



Non original engine parts. OEMs names and part numbers are for reference purpose only.







SAME







1000.3 AT	Cm³	CILINDRI CYLINDERS	ALESAGGIO BORE	CORSA STROKE	VERSIONE VERSION
	3000	3	105	115,5	7787 → 8712

		 0,5 mm	
0.351.0050.6/10		0.085.1450.0	0.085.0057.6
FIN7502CGA	FIN7502CGB	FIN6281HG	FIN3104SM

		 IN	 EX
0.007.0614.0/10	0.069.1450.0/30		
FIN5016CO	FIN3204CB		

Nr.	ENGINE KIT	
1		FIN1991SL00
1		FIN3102PC00
1		FIN3104SM
0.381.0065.A/B		FIN8226KIT

 LV	 LD					
2.1529.073.0	2.1529.141.0	0.87334.51.0	2.4239.100.0	0.010.3279.0	2.4419.340.0	2.4319.060.1
FIN2888RT	FIN2889RT	FIN8030AF	FIN8225PF	FIN8155NF	FIN8230OF	FIN8605FE

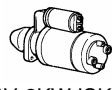
					 14V-35A	 14V-3KW ISKRA
2.4519.300.0		2.4619.030.1	2.4729.100.0	2.4619.010.2	2.9439.220.0/10	2.9619.180.0/10
FIN919FP		FIN1695E	FIN161NO	FIN1690DV	FIN2288VA	FIN201TL

1	Guarnizione testa 0,7 mm	Head Gaket 0,7 mm	0.085.1451.0	FIN6282HG
2	Guarnizione testa 0,8 mm	Head Gaket 0,8 mm	0.085.1453.0	FIN6283HG
3	Guarnizione testa 1,0 mm	Head Gaket 1,0 mm	0.085.1452.0	FIN6284HG
4	OR per canna (117,07X3,53)	Liner O ring (117,07X3,53)	2.1539.130.0/10	FIN1098OR
5	Pompa olio	Oil pump	0.010.5481.4	FIN046OP
6	Kit revisione pompa alimentazione	Fuel pump repairing kit	2.4519.269.0	FIN2919KFP
7	Filtro Aria 6"	Air cleaner 6"	2.4249.250.0/10	FIN8201AF
8	Filtro Aria 8"	Air cleaner 8"	0.87335.51.0	FIN8035AF
9	Filtro Aria (bagno olio)	Air cleaner (oil bath)	0.88329.50.3	FIN8205AF
10	Alternatore 26V-35A	Alternator 26V-35A-ISKRA	2.9439.260.0/10	FIN2305VA
11	Alternatore 14V-65A-ISKRA	Alternator 14V-65A-ISKRA	2.9439.420.0/10	FIN2320VA
12	Motorino d'avviamento 28V-3,2KW ISKRA	Starter engine 28V-3,2KW ISKRA	2.9619.120.0/10	FIN1865TL
13				
14				
15				

Ricambi non originali per motori. Denominazioni e codici originali, sono riportati a puro titolo di riferimento.



4 - 68







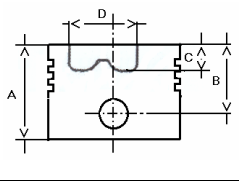

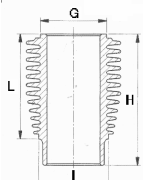
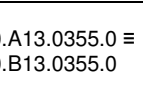
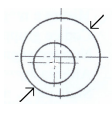
rel. 905

Non original engine parts. OEMs names and part numbers are for reference purpose only.

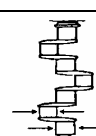
SAME

1000.3 AT	Cm³	CILINDRI CYLINDERS	ALESAGGIO BORE	CORSA STROKE	VERSIONE VERSION
	3000	3	105	115,5	8713 →

		TESTA HEAD	H47		6	3	TIPO TYPE	A	
		A	97,25		4	2,5			G
FIN419PN 0.078.1236.0/10		E	86		23	4	H		194,5
	105	0.381.0060.6	FIN3102PC00		0.338.0052.6/10	FIN2320RS00	I	113	
	105,5		FIN3102PC05	0.338.0053.6/10	FIN2320RS05	L	125,5		
	106				FIN2320RS10	0.A13.0355.0 ≡ 0.B13.0355.0		FIN1991SL00	

		Nr.						ADATTABILE A: SUITABLE FOR:	
---	---	------------	---	---	---	---	---	--------------------------------	---

CR	RP	3	63,50	67,22	29,00		STD - 025 - 050 075 - 100	0.065.1225.0 + 0.065.1225.0	FIN478CR STD
----	----	---	-------	-------	-------	--	------------------------------	--------------------------------	--------------

MB	RP	4	70,00	74,02	26,25		STD - 025 - 050 075 - 100	0.065.1215.0 + 0.065.1216.0	FIN279MB STD
----	----	---	-------	-------	-------	--	------------------------------	--------------------------------	--------------





--	--	--	--	--	--	--	--	--	--



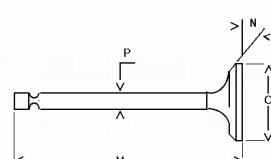

--	--	--	--	--	--	--	--	--	--

PB	BM	3	35,00	39,02	34,65		SEMIF.	2.1559.114.0/10	FIN110PB
----	----	---	-------	-------	-------	--	--------	-----------------	----------

TWS	AL	2	82,25	100,00	2,36		STD - 010 - 020	0.065.1218.0 + 0.065.1218.0	FIN167TWS STD
-----	----	---	-------	--------	------	--	-----------------	--------------------------------	---------------

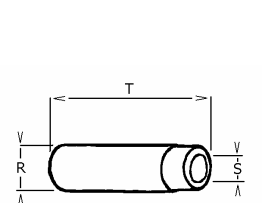
--	--	--	--	--	--	--	--	--	--

	IN EX		Nr.	O	P	M	N		ADATTABILE A: SUITABLE FOR:			
	IN		FR	3	44	9	131		30°	A1	0.010.6017.0	FINA6041
	EX		FSN	3	39,5	9	130,5		45°	A1	0.010.6022.0	FINS6042

	IN EX		Nr.	R	S	T		ADATTABILE A: SUITABLE FOR:			
	IN		G	3	15,03	9,02		60	I	0.007.1779.0/10	FIN6519ASA
	EX		G	3	15,03	9,02		60	I	0.007.1779.0/10	FIN6519ASA
	EX										

Ricambi non originali per motori. Denominazioni e codici originali, sono riportati a puro titolo di riferimento.





5 - 68





rel. 905



Non original engine parts. OEMs names and part numbers are for reference purpose only.







SAME







1000.3 AT	Cm³	CILINDRI CYLINDERS	ALESAGGIO BORE	CORSA STROKE	VERSIONE VERSION
	3000	3	105	115,5	8713 →

		 0,5 mm	
0.351.0050.6/10		0.085.1450.0	0.085.0057.6
FIN7502CGA	FIN7502CGB	FIN6281HG	FIN3104SM

		 IN	 EX
0.007.0614.0/10	0.069.1450.0/30		
FIN5016CO	FIN3204CB		

Nr.	ENGINE KIT	
1		FIN1991SL00
1		FIN3102PC00
1		FIN3104SM
0.381.0065.A/B		FIN8226KIT

 LV	 LD					
2.1529.073.0	2.1529.141.0	0.87334.51.0	2.4239.100.0	0.010.3279.0	2.4419.340.0	2.4319.060.1
FIN2888RT	FIN2889RT	FIN8030AF	FIN8225PF	FIN8155NF	FIN8230OF	FIN8605FE

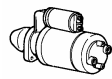
					 14V-35A	 14V-3KW ISKRA
2.4519.300.0		2.4619.030.1	2.4729.100.0	2.4619.010.2	2.9439.220.0/10	2.9619.180.0/10
FIN919FP		FIN1695E	FIN161NO	FIN1690DV	FIN2288VA	FIN201TL

1	Guarnizione testa 0,7 mm	Head Gaket 0,7 mm	0.085.1451.0	FIN6282HG
2	Guarnizione testa 0,8 mm	Head Gaket 0,8 mm	0.085.1453.0	FIN6283HG
3	Guarnizione testa 1,0 mm	Head Gaket 1,0 mm	0.085.1452.0	FIN6284HG
4	OR per canna (117,07X3,53)	Liner O ring (117,07X3,53)	2.1539.130.0/10	FIN1098OR
5	Pompa olio	Oil pump	0.010.5481.4	FIN046OP
6	Kit revisione pompa alimentazione	Fuel pump repairing kit	2.4519.269.0	FIN2919KFP
7	Filtro Aria 6"	Air cleaner 6"	2.4249.250.0/10	FIN8201AF
8	Filtro Aria 8"	Air cleaner 8"	0.87335.51.0	FIN8035AF
9	Filtro Aria (bagno olio)	Air cleaner (oil bath)	0.88329.50.3	FIN8205AF
10	Alternatore 26V-35A	Alternator 26V-35A-ISKRA	2.9439.260.0/10	FIN2305VA
11	Alternatore 14V-65A-ISKRA	Alternator 14V-65A-ISKRA	2.9439.420.0/10	FIN2320VA
12	Motorino d'avviamento 28V-3,2KW ISKRA	Starter engine 28V-3,2KW ISKRA	2.9619.120.0/10	FIN1865TL
13				
14				
15				

Ricambi non originali per motori. Denominazioni e codici originali, sono riportati a puro titolo di riferimento.



6 - 68





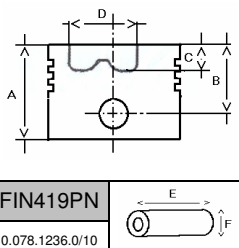

rel. 905

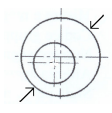
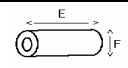
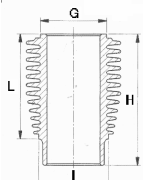
Non original engine parts. OEMs names and part numbers are for reference purpose only.

SAME

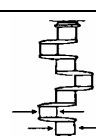
1000.3 AT-POT	Cm³	CILINDRI CYLINDERS	ALESAGGIO BORE	CORSA STROKE	VERSIONE VERSION
	3000	3	105	115,5	7786 ←

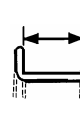
		TESTA HEAD	H22		6	3	TIPO TYPE	A	
					4	2,5			
	FIN419PN 0.078.1236.0/10		A 97,25 B 57,25 C 20,85 D 60 E 86 F 35	G 115,5 H 194,5 I 113 L 125,5	23	4		FIN1991SL00	
					105	0.338.0060.6/20			
	105,5	0.338.0061.6/20	FIN2404PC05	0.338.0053.6/10	FIN2320RS05		0.007.0762.0/40 ≡ 0.007.0762.0/50		
	106				FIN2320RS10				

		Nr.						ADATTABILE A: SUITABLE FOR:	
---	---	------------	---	---	---	---	---	--------------------------------	---

CR	RP	3	63,50	67,22	29,00		STD - 025 - 050 075 - 100	0.065.1225.0 + 0.065.1225.0	FIN478CR STD
----	----	---	-------	-------	-------	--	------------------------------	--------------------------------	--------------

MB	RP	4	70,00	74,02	26,25		STD - 025 - 050 075 - 100	0.065.1215.0 + 0.065.1216.0	FIN279MB STD
----	----	---	-------	-------	-------	--	------------------------------	--------------------------------	--------------





--	--	--	--	--	--	--	--	--	--



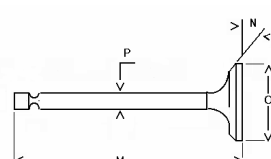

--	--	--	--	--	--	--	--	--	--

PB	BM	3	35,00	39,02	34,65		SEMIF.	2.1559.114.0/10	FIN110PB
----	----	---	-------	-------	-------	--	--------	-----------------	----------

TWS	AL	2	82,25	100,00	2,36		STD - 010 - 020	0.065.1218.0 + 0.065.1218.0	FIN167TWS STD
-----	----	---	-------	--------	------	--	-----------------	--------------------------------	---------------

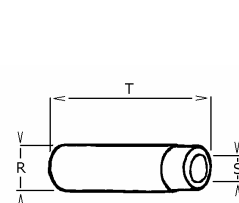
--	--	--	--	--	--	--	--	--	--

		Nr.	O	P	M	N		ADATTABILE A: SUITABLE FOR:									
								IN	FR	3	44	9	131	30°	A1	0.010.6017.0	FINA6041
								EX	FSN	3	39,5	9	130,5	45°	A1	0.010.6022.0	FINS6042

		Nr.	R	S	T		ADATTABILE A: SUITABLE FOR:								
							IN	G	3	15,03	9,02	60	I	0.007.1779.0/10	FIN6519ASA
							IN								
							EX	G	3	15,03	9,02	60	I	0.007.1779.0/10	FIN6519ASA
EX															

Ricambi non originali per motori. Denominazioni e codici originali, sono riportati a puro titolo di riferimento.





7 - 68





rel. 905



Non original engine parts. OEMs names and part numbers are for reference purpose only.







SAME







1000.3 AT-POT	Cm³	CILINDRI CYLINDERS	ALESAGGIO BORE	CORSA STROKE	VERSIONE VERSION
	3000	3	105	115,5	7786 ←

		 0,5 mm	
0.351.0050.6/10		0.085.1450.0	0.085.0057.6
FIN7502CGA	FIN7502CGB	FIN6281HG	FIN3104SM

		 IN	 EX
0.007.0614.0/10	0.069.1450.0/30		
FIN5016CO	FIN3204CB		

Nr.	ENGINE KIT	
1		FIN1991SL00
1		FIN2404PC00
1		FIN3104SM
0.338.0065.6/20		FIN2051KIT

 LV	 LD					
2.1529.073.0	2.1529.141.0	0.87334.51.0			2.4419.340.0	2.4319.060.1
FIN2888RT	FIN2889RT	FIN8030AF			FIN8230OF	FIN8605FE

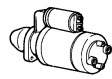
					 14V-35A	 14V-3KW ISKRA
2.4519.300.0		0.009.4340.1	2.4729.140.0	0.010.2630.0	2.9439.220.0/10	2.9619.180.0/10
FIN919FP		FIN1699E	FIN1720NO	FIN1698DV	FIN2288VA	FIN201TL

1	Guarnizione testa 0,7 mm	Head Gaket 0,7 mm	0.085.1451.0	FIN6282HG
2	Guarnizione testa 0,8 mm	Head Gaket 0,8 mm	0.085.1453.0	FIN6283HG
3	Guarnizione testa 1,0 mm	Head Gaket 1,0 mm	0.085.1452.0	FIN6284HG
4	OR per canna (117,07X3,53)	Liner O ring (117,07X3,53)	2.1539.130.0/10	FIN1098OR
5	Pompa olio	Oil pump	0.010.5481.4	FIN046OP
6	Kit revisione pompa alimentazione	Fuel pump repairing kit	2.4519.269.0	FIN2919KFP
7	Filtro Aria 6"	Air cleaner 6"	2.4249.250.0/10	FIN8201AF
8	Alternatore 26V-35A	Alternator 26V-35A-ISKRA	2.9439.260.0/10	FIN2305VA
9	Motorino d'avviamento 28V-3,2KW ISKRA	Starter engine 28V-3,2KW ISKRA	2.9619.120.0/10	FIN1865TL
10				
11				
12				
13				
14				
15				

Ricambi non originali per motori. Denominazioni e codici originali, sono riportati a puro titolo di riferimento.







8 - 68



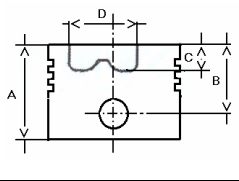

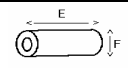

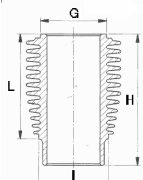

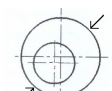
rel. 905

Non original engine parts. OEMs names and part numbers are for reference purpose only.

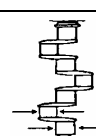
SAME

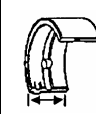
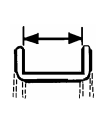
1000.3 AT-POT	Cm³	CILINDRI CYLINDERS	ALESAGGIO BORE	CORSA STROKE	VERSIONE VERSION
	3000	3	105	115,5	7787 → 8712

		TESTA HEAD	H47		6	3	TIPO TYPE	A	
		A	97,25		4	2,5			
	FIN419PN	E	86		23	4		G	115,5
	0.078.1236.0/10	F	35						H
	105	0.381.0060.6	FIN3102PC00	0.338.0052.6/10		FIN2320RS00		0.007.0762.0/40 ≡ 0.007.0762.0/50	I
	105,5		FIN3102PC05	0.338.0053.6/10	FIN2320RS05		L		125,5
	106				FIN2320RS10		FIN1991SL00		

		Nr.							ADATTABILE A: SUITABLE FOR:	
---	---	------------	---	---	---	---	---	--	--------------------------------	---

CR	RP	3	63,50	67,22	29,00			STD - 025 - 050 075 - 100	0.065.1225.0 + 0.065.1225.0	FIN478CR STD
----	----	---	-------	-------	-------	--	--	------------------------------	--------------------------------	--------------

MB	RP	4	70,00	74,02	26,25			STD - 025 - 050 075 - 100	0.065.1215.0 + 0.065.1216.0	FIN279MB STD
----	----	---	-------	-------	-------	--	--	------------------------------	--------------------------------	--------------





--	--	--	--	--	--	--	--	--	--	--



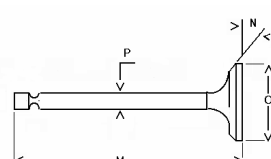

--	--	--	--	--	--	--	--	--	--	--

PB	BM	3	35,00	39,02	34,65			SEMIF.	2.1559.114.0/10	FIN110PB
----	----	---	-------	-------	-------	--	--	--------	-----------------	----------

TWS	AL	2	82,25	100,00	2,36			STD - 010 - 020	0.065.1218.0 + 0.065.1218.0	FIN167TWS STD
-----	----	---	-------	--------	------	--	--	-----------------	--------------------------------	---------------

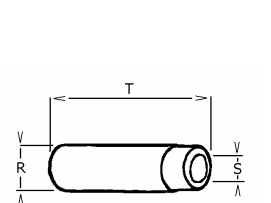
--	--	--	--	--	--	--	--	--	--	--

	IN EX		Nr.	O	P	M	N		ADATTABILE A: SUITABLE FOR:			
	IN		FR	3	44	9	131		30°	A1	0.010.6017.0	FINA6041
	EX		FSN	3	39,5	9	130,5		45°	A1	0.010.6022.0	FINS6042

	IN EX		Nr.	R	S	T		ADATTABILE A: SUITABLE FOR:			
	IN		G	3	15,02	9,02		60	I	0.007.1779.0/10	FIN6519ASA
	EX		G	3	15,03	9,02		60	I	0.007.1779.0/10	FIN6519ASA
	EX										

Ricambi non originali per motori. Denominazioni e codici originali, sono riportati a puro titolo di riferimento.





9 - 68





rel. 905



Non original engine parts. OEMs names and part numbers are for reference purpose only.







SAME







1000.3 AT-POT	Cm³	CILINDRI CYLINDERS	ALESAGGIO BORE	CORSA STROKE	VERSIONE VERSION
	3000	3	105	115,5	7787 → 8712

		 0,5 mm	
0.351.0050.6/10		0.085.1450.0	0.085.0057.6
FIN7502CGA	FIN7502CGB	FIN6281HG	FIN3104SM

		 IN	 EX
0.007.0614.0/10	0.069.1450.0/30		
FIN5016CO	FIN3204CB		

Nr.	ENGINE KIT	
1		FIN1991SL00
1		FIN3102PC00
1		FIN3104SM
0.381.0065.A/B		FIN8226KIT

 LV	 LD					
2.1529.073.0	2.1529.141.0	0.87334.51.0			2.4419.340.0	2.4319.060.1
FIN2888RT	FIN2889RT	FIN8030AF			FIN8230OF	FIN8605FE

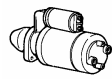
					 14V-35A	 14V-3KW ISKRA
2.4519.300.0		0.009.4340.1	2.4729.140.0	0.010.2630.0	2.9439.220.0/10	2.9619.180.0/10
FIN919FP		FIN1699E	FIN1720NO	FIN1698DV	FIN2288VA	FIN201TL

1	Guarnizione testa 0,7 mm	Head Gaket 0,7 mm	0.085.1451.0	FIN6282HG
2	Guarnizione testa 0,8 mm	Head Gaket 0,8 mm	0.085.1453.0	FIN6283HG
3	Guarnizione testa 1,0 mm	Head Gaket 1,0 mm	0.085.1452.0	FIN6284HG
4	OR per canna (117,07X3,53)	Liner O ring (117,07X3,53)	2.1539.130.0/10	FIN1098OR
5	Pompa olio	Oil pump	0.010.5481.4	FIN046OP
6	Kit revisione pompa alimentazione	Fuel pump repairing kit	2.4519.269.0	FIN2919KFP
7	Filtro Aria 6"	Air cleaner 6"	2.4249.250.0/10	FIN8201AF
8	Alternatore 26V-35A	Alternator 26V-35A-ISKRA	2.9439.260.0/10	FIN2305VA
9	Motorino d'avviamento 28V-3,2KW ISKRA	Starter engine 28V-3,2KW ISKRA	2.9619.120.0/10	FIN1865TL
10				
11				
12				
13				
14				
15				

Ricambi non originali per motori. Denominazioni e codici originali, sono riportati a puro titolo di riferimento.





10 - 68





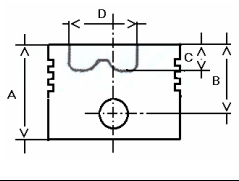

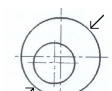
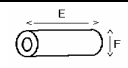
rel. 905

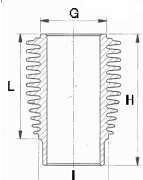
Non original engine parts. OEMs names and part numbers are for reference purpose only.

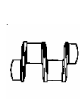
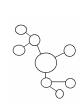
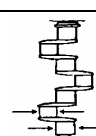
SAME

1000.3 AT-POT	Cm³	CILINDRI CYLINDERS	ALESAGGIO BORE	CORSA STROKE	VERSIONE VERSION
	3000	3	105	115,5	8713 →

		TESTA HEAD	H47		6	3	TIPO TYPE	A	
					4	2,5			
	FIN419PN 0.078.1236.0/10		E 86 F 35		23	4		G	115,5
					105	0.381.0060.6		FIN3102PC00	0.338.0052.6/10
	105,5		FIN3102PC05	0.338.0053.6/10	FIN2320RS05	I	113	L	125,5
	106				FIN2320RS10				
							0.A13.0355.0 ≡ 0.B13.0355.0	FIN1991SL00	

		Nr.						ADATTABILE A: SUITABLE FOR:	
---	---	------------	---	---	---	---	---	--------------------------------	---

CR	RP	3	63,50	67,22	29,00		STD - 025 - 050 075 - 100	0.065.1225.0 + 0.065.1225.0	FIN478CR STD
----	----	---	-------	-------	-------	--	------------------------------	--------------------------------	--------------

MB	RP	4	70,00	74,02	26,25		STD - 025 - 050 075 - 100	0.065.1215.0 + 0.065.1216.0	FIN279MB STD
----	----	---	-------	-------	-------	--	------------------------------	--------------------------------	--------------





--	--	--	--	--	--	--	--	--	--



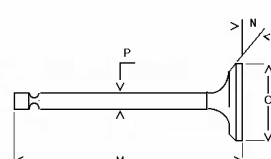

--	--	--	--	--	--	--	--	--	--

PB	BM	3	35,00	39,02	34,65		SEMIF.	2.1559.114.0/10	FIN110PB
----	----	---	-------	-------	-------	--	--------	-----------------	----------

TWS	AL	2	82,25	100,00	2,36		STD - 010 - 020	0.065.1218.0 + 0.065.1218.0	FIN167TWS STD
-----	----	---	-------	--------	------	--	-----------------	--------------------------------	---------------

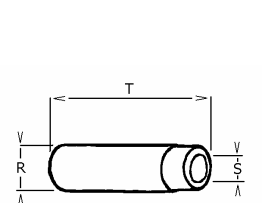
--	--	--	--	--	--	--	--	--	--

	IN		Nr.	O	P	M	N		ADATTABILE A: SUITABLE FOR:								
	IN								FR	3	44	9	131	30°	A1	0.010.6017.0	FINA6041
	EX								FSN	3	39,5	9	130,5	45°	A1	0.010.6022.0	FINS6042

	IN		Nr.	R	S	T		ADATTABILE A: SUITABLE FOR:							
	IN							G	3	15,03	9,02	60	I	0.007.1779.0/10	FIN6519ASA
	EX							G	3	15,03	9,02	60	I	0.007.1779.0/10	FIN6519ASA
	EX														

Ricambi non originali per motori. Denominazioni e codici originali, sono riportati a puro titolo di riferimento.





11 - 68





rel. 905



Non original engine parts. OEMs names and part numbers are for reference purpose only.







SAME







1000.3 AT-POT	Cm³	CILINDRI CYLINDERS	ALESAGGIO BORE	CORSA STROKE	VERSIONE VERSION
	3000	3	105	115,5	8713 →

		 0,5 mm	
0.351.0050.6/10		0.085.1450.0	0.085.0057.6
FIN7502CGA	FIN7502CGB	FIN6281HG	FIN3104SM

		 IN	 EX
0.007.0614.0/10	0.069.1450.0/30		
FIN5016CO	FIN3204CB		

Nr.	ENGINE KIT	
1		FIN1991SL00
1		FIN3102PC00
1		FIN3104SM
0.381.0065.A/B		FIN8226KIT

 LV	 LD					
2.1529.073.0	2.1529.141.0	0.87334.51.0			2.4419.340.0	2.4319.060.1
FIN2888RT	FIN2889RT	FIN8030AF			FIN8230OF	FIN8605FE

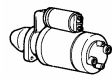
					 14V-35A	 14V-3KW ISKRA
2.4519.300.0		0.009.4340.1	2.4729.140.0	0.010.2630.0	2.9439.220.0/10	2.9619.180.0/10
FIN919FP		FIN1699E	FIN1720NO	FIN1698DV	FIN2288VA	FIN201TL

1	Guarnizione testa 0,7 mm	Head Gaket 0,7 mm	0.085.1451.0	FIN6282HG
2	Guarnizione testa 0,8 mm	Head Gaket 0,8 mm	0.085.1453.0	FIN6283HG
3	Guarnizione testa 1,0 mm	Head Gaket 1,0 mm	0.085.1452.0	FIN6284HG
4	OR per canna (117,07X3,53)	Liner O ring (117,07X3,53)	2.1539.130.0/10	FIN1098OR
5	Pompa olio	Oil pump	0.010.5481.4	FIN046OP
6	Kit revisione pompa alimentazione	Fuel pump repairing kit	2.4519.269.0	FIN2919KFP
7	Filtro Aria 6"	Air cleaner 6"	2.4249.250.0/10	FIN8201AF
8	Alternatore 26V-35A	Alternator 26V-35A-ISKRA	2.9439.260.0/10	FIN2305VA
9	Motorino d'avviamento 28V-3,2KW ISKRA	Starter engine 28V-3,2KW ISKRA	2.9619.120.0/10	FIN1865TL
10				
11				
12				
13				
14				
15				

Ricambi non originali per motori. Denominazioni e codici originali, sono riportati a puro titolo di riferimento.



12 - 68







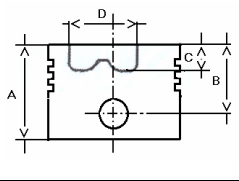

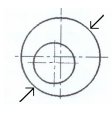
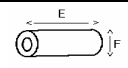
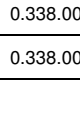
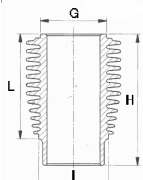
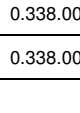
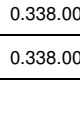
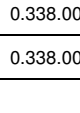
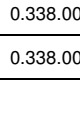
rel. 905

Non original engine parts. OEMs names and part numbers are for reference purpose only.

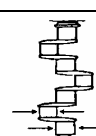
SAME

1000.4 AT	Cm³	CILINDRI CYLINDERS	ALESAGGIO BORE	CORSA STROKE	VERSIONE VERSION
	4000	4	105	115,5	18772 ←

		TESTA HEAD	H22		6	3	TIPO TYPE	A		
		A	97,25		4	2,5				
	FIN419PN		E	86		23	4		G	115,5
	0.078.1236.0/10		F	35						
105	0.338.0060.6/20	FIN2404PC00	0.338.0052.6/10	FIN2320RS00	0.007.0762.0/40 ≡ 0.007.0762.0/50			FIN1991SL00		
105,5	0.338.0061.6/20	FIN2404PC05	0.338.0053.6/10	FIN2320RS05		L	125,5			
106				FIN2320RS10						

		Nr.						ADATTABILE A: SUITABLE FOR:	
---	---	------------	---	---	---	---	---	--------------------------------	---

CR	RP	4	63,50	67,22	29,00		STD - 025 - 050 075 - 100	0.065.1225.0 + 0.065.1225.0	FIN478CR STD
----	----	---	-------	-------	-------	--	------------------------------	--------------------------------	--------------

MB	RP	5	70,00	74,02	26,25		STD - 025 - 050 075 - 100	0.065.1215.0 + 0.065.1216.0	FIN279MB STD
----	----	---	-------	-------	-------	--	------------------------------	--------------------------------	--------------





--	--	--	--	--	--	--	--	--	--



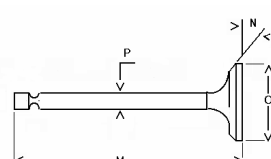

--	--	--	--	--	--	--	--	--	--

PB	BM	4	35,00	39,02	34,65		SEMIF.	2.1559.114.0/10	FIN110PB
----	----	---	-------	-------	-------	--	--------	-----------------	----------

TWS	AL	2	82,25	100,00	2,36		STD - 010 - 020	0.065.1218.0 + 0.065.1218.0	FIN167TWS STD
-----	----	---	-------	--------	------	--	-----------------	--------------------------------	---------------

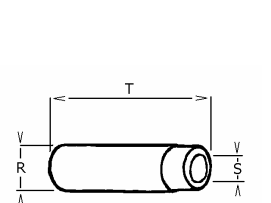
--	--	--	--	--	--	--	--	--	--

	IN EX		Nr.	O	P	M	N		ADATTABILE A: SUITABLE FOR:			
	IN		FR	4	44	9	131		30°	A1	0.010.6017.0	FINA6041
	EX		FSN	4	39,5	9	130,5		45°	A1	0.010.6022.0	FINS6042

	IN EX		Nr.	R	S	T		ADATTABILE A: SUITABLE FOR:			
	IN		G	4	15,03	9,02		60	I	0.007.1779.0/10	FIN6519ASA
	EX		G	4	15,03	9,02		60	I	0.007.1779.0/10	FIN6519ASA
	EX										

Ricambi non originali per motori. Denominazioni e codici originali, sono riportati a puro titolo di riferimento.





13 - 68





rel. 905



Non original engine parts. OEMs names and part numbers are for reference purpose only.







SAME







1000.4 AT	Cm³	CILINDRI CYLINDERS	ALESAGGIO BORE	CORSA STROKE	VERSIONE VERSION
	4000	4	105	115,5	18772 ←

		 0,5 mm	
0.087.0050.6/10		0.085.1450.0	0.085.0057.6
FIN7503CGA	FIN7503CGB	FIN6281HG	FIN3104SM

		 IN	 EX
0.065.1571.0	0.065.1450.0/30		
FIN5009CO	FIN3208CB		

Nr.	ENGINE KIT	
1		FIN1991SL00
1		FIN2404PC00
1		FIN3104SM
0.338.0065.6/20		FIN2051KIT

 LV	 LD					
2.1529.073.0	2.1529.141.0	2.4249.130.0/10	2.4239.100.0	0.010.3283.1	2.4419.340.0	2.4319.060.1
FIN2888RT	FIN2889RT	FIN8244AF	FIN8225PF	FIN8124NF	FIN8230OF	FIN8605FE

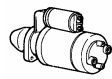
					 26V-35A	 14V-3KW ISKRA
2.4519.300.0		2.4619.030.1	2.4729.100.0	2.4619.010.2	2.9439.260.0/10	2.9619.180.0/10
FIN919FP		FIN1695E	FIN161NO	FIN1690DV	FIN2305VA	FIN201TL

1	Guarnizione testa 0,7 mm	Head Gaket 0,7 mm	0.085.1451.0	FIN6282HG
2	Guarnizione testa 0,8 mm	Head Gaket 0,8 mm	0.085.1453.0	FIN6283HG
3	Guarnizione testa 1,0 mm	Head Gaket 1,0 mm	0.085.1452.0	FIN6284HG
4	OR per canna (117,07X3,53)	Liner O ring (117,07X3,53)	2.1539.130.0/10	FIN1098OR
5	Pompa olio	Oil pump	0.010.5441.4/10	FIN047OP
6	Kit revisione pompa alimentazione	Fuel pump repairing kit	2.4519.269.0	FIN2919KFP
7	Filtro Aria 8"	Air cleaner 8"	0.87335.51.0	FIN8035AF
8	Filtro Aria 6"	Air cleaner 6"	0.87334.51.0	FIN8030AF
9	Massa filtrante 6"	Filtering element 6"	0.010.3284.2	FIN8145NF
10	Motorino d'avviamento 28V-3,2KW ISKRA	Starter engine 28V-3,2KW ISKRA	2.9619.120.0/10	FIN1865TL
11	Alternatore 14V-65A-ISKRA	Alternator 14V-65A-ISKRA	2.9439.420.0/10	FIN2320VA
12				
13				
14				
15				

Ricambi non originali per motori. Denominazioni e codici originali, sono riportati a puro titolo di riferimento.



14 - 68







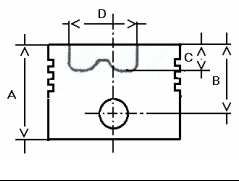

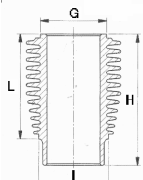
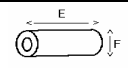
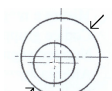
rel. 905

Non original engine parts. OEMs names and part numbers are for reference purpose only.

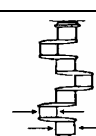
SAME

1000.4 AT	Cm³	CILINDRI CYLINDERS	ALESAGGIO BORE	CORSA STROKE	VERSIONE VERSION
	4000	4	105	115,5	18773 → 21296

		TESTA HEAD	H47		6	3	TIPO TYPE 	A	
		A	97,25		4	2,5			
		B	57,25		23	4			
		C	20,85						
FIN419PN 0.078.1236.0/10			E	86					
			F	35					
	105	0.381.0060.6	FIN3102PC00		0.338.0052.6/10	FIN2320RS00			
	105,5		FIN3102PC05		0.338.0053.6/10	FIN2320RS05			
	106					FIN2320RS10			
					0.007.0762.0/40 ≡ 0.007.0762.0/50		FIN1991SL00		

		Nr.						ADATTABILE A: SUITABLE FOR:	
---	---	------------	---	---	---	---	---	--------------------------------	---

CR	RP	4	63,50	67,22	29,00		STD - 025 - 050 075 - 100	0.065.1225.0 + 0.065.1225.0	FIN478CR STD
----	----	---	-------	-------	-------	--	------------------------------	--------------------------------	--------------

MB	RP	5	70,00	74,02	26,25		STD - 025 - 050 075 - 100	0.065.1215.0 + 0.065.1216.0	FIN279MB STD
----	----	---	-------	-------	-------	--	------------------------------	--------------------------------	--------------





--	--	--	--	--	--	--	--	--	--



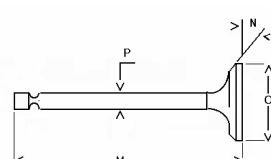

--	--	--	--	--	--	--	--	--	--

PB	BM	4	35,00	39,02	34,65		SEMIF.	2.1559.114.0/10	FIN110PB
----	----	---	-------	-------	-------	--	--------	-----------------	----------

TWS	AL	2	82,25	100,00	2,36		STD - 010 - 020	0.065.1218.0 + 0.065.1218.0	FIN167TWS STD
-----	----	---	-------	--------	------	--	-----------------	--------------------------------	---------------

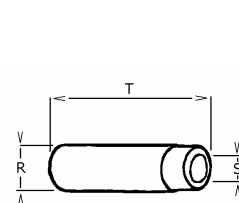
--	--	--	--	--	--	--	--	--	--

	IN EX		Nr.	O	P	M	N		ADATTABILE A: SUITABLE FOR:			
	IN		FR	4	44	9	131		30°	A1	0.010.6017.0	FINA6041
	EX		FSN	4	39,5	9	130,5		45°	A1	0.010.6022.0	FINS6042

	IN EX		Nr.	R	S	T		ADATTABILE A: SUITABLE FOR:			
	IN		G	4	15,03	9,02		60	I	0.007.1779.0/10	FIN6519ASA
	IN										
	EX		G	4	15,03	9,02		60	I	0.007.1779.0/10	FIN6519ASA
EX											

Ricambi non originali per motori. Denominazioni e codici originali, sono riportati a puro titolo di riferimento.





15 - 68





rel. 905



Non original engine parts. OEMs names and part numbers are for reference purpose only.







SAME







1000.4 AT	Cm³	CILINDRI CYLINDERS	ALESAGGIO BORE	CORSA STROKE	VERSIONE VERSION
	4000	4	105	115,5	18773 → 21296

		 0,5 mm	
0.087.0050.6/10		0.085.1450.0	0.085.0057.6
FIN7503CGA	FIN7503CGB	FIN6281HG	FIN3104SM

		 IN	 EX
0.065.1571.0	0.065.1450.0/30		
FIN5009CO	FIN3208CB		

Nr.	ENGINE KIT	
1		FIN1991SL00
1		FIN3102PC00
1		FIN3104SM
0.381.0065.A/B		FIN8226KIT

 LV	 LD					
2.1529.073.0	2.1529.141.0	2.4249.130.0/10	2.4239.100.0	0.010.3283.1	2.4419.340.0	2.4319.060.1
FIN2888RT	FIN2889RT	FIN8244AF	FIN8225PF	FIN8124NF	FIN8230OF	FIN8605FE

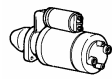
					 26V-35A	 14V-3KW ISKRA
2.4519.300.0		2.4619.030.1	2.4729.100.0	2.4619.010.2	2.9439.260.0/10	2.9619.180.0/10
FIN919FP		FIN1695E	FIN161NO	FIN1690DV	FIN2305VA	FIN201TL

1	Guarnizione testa 0,7 mm	Head Gaket 0,7 mm	0.085.1451.0	FIN6282HG
2	Guarnizione testa 0,8 mm	Head Gaket 0,8 mm	0.085.1453.0	FIN6283HG
3	Guarnizione testa 1,0 mm	Head Gaket 1,0 mm	0.085.1452.0	FIN6284HG
4	OR per canna (117,07X3,53)	Liner O ring (117,07X3,53)	2.1539.130.0/10	FIN1098OR
5	Pompa olio	Oil pump	0.010.5441.4/10	FIN047OP
6	Kit revisione pompa alimentazione	Fuel pump repairing kit	2.4519.269.0	FIN2919KFP
7	Filtro Aria 8"	Air cleaner 8"	0.87335.51.0	FIN8035AF
8	Filtro Aria 6"	Air cleaner 6"	0.87334.51.0	FIN8030AF
9	Massa filtrante 6"	Filtering element 6"	0.010.3284.2	FIN8145NF
10	Motorino d'avviamento 28V-3,2KW ISKRA	Starter engine 28V-3,2KW ISKRA	2.9619.120.0/10	FIN1865TL
11	Alternatore 14V-65A-ISKRA	Alternator 14V-65A-ISKRA	2.9439.420.0/10	FIN2320VA
12				
13				
14				
15				

Ricambi non originali per motori. Denominazioni e codici originali, sono riportati a puro titolo di riferimento.





16 - 68





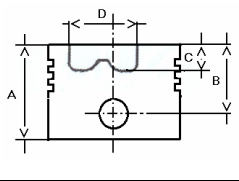

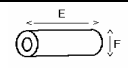

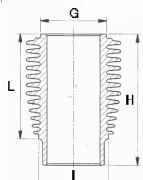
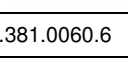
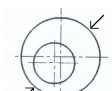
rel. 905

Non original engine parts. OEMs names and part numbers are for reference purpose only.

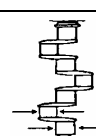
SAME

1000.4 AT	Cm³	CILINDRI CYLINDERS	ALESAGGIO BORE	CORSA STROKE	VERSIONE VERSION
	4000	4	105	115,5	21297 →

		TESTA HEAD	H47		6	3	TIPO TYPE	A	
		A	97,25		4	2,5			
	FIN419PN	E	86		23	4		G	115,5
	0.078.1236.0/10	F	35						H
	105	0.381.0060.6	FIN3102PC00	0.338.0052.6/10		FIN2320RS00		I	113
	105,5		FIN3102PC05	0.338.0053.6/10	FIN2320RS05		L	125,5	
	106				FIN2320RS10		0.A13.0355.0 ≡ 0.B13.0355.0		FIN1991SL00

		Nr.						ADATTABILE A: SUITABLE FOR:	
---	---	------------	---	---	---	---	---	--------------------------------	---

CR	RP	4	63,50	67,22	29,00		STD - 025 - 050 075 - 100	0.065.1225.0 + 0.065.1225.0	FIN478CR STD
----	----	---	-------	-------	-------	--	------------------------------	--------------------------------	--------------

MB	RP	5	70,00	74,02	26,25		STD - 025 - 050 075 - 100	0.065.1215.0 + 0.065.1216.0	FIN279MB STD
----	----	---	-------	-------	-------	--	------------------------------	--------------------------------	--------------





--	--	--	--	--	--	--	--	--	--



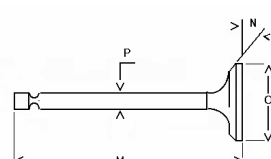

--	--	--	--	--	--	--	--	--	--

PB	BM	4	35,00	39,02	34,65		SEMIF.	2.1559.114.0/10	FIN110PB
----	----	---	-------	-------	-------	--	--------	-----------------	----------

TWS	AL	2	82,25	100,00	2,36		STD - 010 - 020	0.065.1218.0 + 0.065.1218.0	FIN167TWS STD
-----	----	---	-------	--------	------	--	-----------------	--------------------------------	---------------

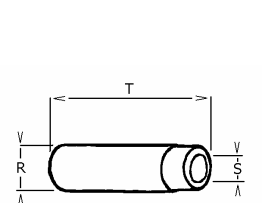
--	--	--	--	--	--	--	--	--	--

	IN EX		Nr.	O	P	M	N		ADATTABILE A: SUITABLE FOR:			
	IN		FR	4	44	9	131		30°	A1	0.010.6017.0	FINA6041
	EX		FSN	4	39,5	9	130,5		45°	A1	0.010.6022.0	FINS6042

	IN EX		Nr.	R	S	T		ADATTABILE A: SUITABLE FOR:			
	IN		G	4	15,03	9,02		60	I	0.007.1779.0/10	FIN6519ASA
	EX		G	4	15,03	9,02		60	I	0.007.1779.0/10	FIN6519ASA
	EX										

Ricambi non originali per motori. Denominazioni e codici originali, sono riportati a puro titolo di riferimento.





17 - 68





rel. 905



Non original engine parts. OEMs names and part numbers are for reference purpose only.







SAME







1000.4 AT	Cm³	CILINDRI CYLINDERS	ALESAGGIO BORE	CORSA STROKE	VERSIONE VERSION
	4000	4	105	115,5	21297 →

		 0,5 mm	
0.087.0050.6/10		0.085.1450.0	0.085.0057.6
FIN7503CGA	FIN7503CGB	FIN6281HG	FIN3104SM

		 IN	 EX
0.065.1571.0	0.065.1450.0/30		
FIN5009CO	FIN3208CB		

Nr.	ENGINE KIT	
1		FIN1991SL00
1		FIN3102PC00
1		FIN3104SM
0.381.0065.A/B		FIN8226KIT

 LV	 LD					
2.1529.073.0	2.1529.141.0	2.4249.130.0/10	2.4239.100.0	0.010.3283.1	2.4419.340.0	2.4319.060.1
FIN2888RT	FIN2889RT	FIN8244AF	FIN8225PF	FIN8124NF	FIN8230OF	FIN8605FE

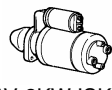
					 26V-35A	 14V-3KW ISKRA
2.4519.300.0		2.4619.030.1	2.4729.170.0/10	2.4619.010.2	2.9439.260.0/10	2.9619.180.0/10
FIN919FP		FIN1695E	FIN1725NO	FIN1690DV	FIN2305VA	FIN201TL

1	Guarnizione testa 0,7 mm	Head Gaket 0,7 mm	0.085.1451.0	FIN6282HG
2	Guarnizione testa 0,8 mm	Head Gaket 0,8 mm	0.085.1453.0	FIN6283HG
3	Guarnizione testa 1,0 mm	Head Gaket 1,0 mm	0.085.1452.0	FIN6284HG
4	OR per canna (117,07X3,53)	Liner O ring (117,07X3,53)	2.1539.130.0/10	FIN1098OR
5	Pompa olio	Oil pump	0.010.5441.4/10	FIN047OP
6	Kit revisione pompa alimentazione	Fuel pump repairing kit	2.4519.269.0	FIN2919KFP
7	Filtro Aria 8"	Air cleaner 8"	0.87335.51.0	FIN8035AF
8	Filtro Aria 6"	Air cleaner 6"	0.87334.51.0	FIN8030AF
9	Massa filtrante 6"	Filtering element 6"	0.010.3284.2	FIN8145NF
10	Motorino d'avviamento 28V-3,2KW ISKRA	Starter engine 28V-3,2KW ISKRA	2.9619.120.0/10	FIN1865TL
11	Alternatore 14V-65A-ISKRA	Alternator 14V-65A-ISKRA	2.9439.420.0/10	FIN2320VA
12				
13				
14				
15				

Ricambi non originali per motori. Denominazioni e codici originali, sono riportati a puro titolo di riferimento.



18 - 68







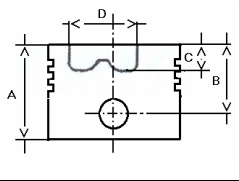

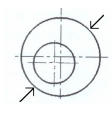
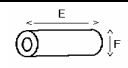
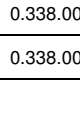
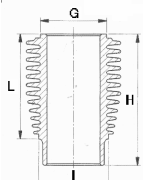
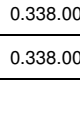
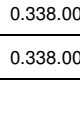
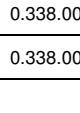
rel. 905

Non original engine parts. OEMs names and part numbers are for reference purpose only.

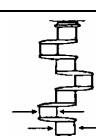
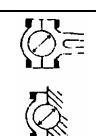
SAME

1000.4 AT1	Cm³	CILINDRI CYLINDERS	ALESAGGIO BORE	CORSA STROKE	VERSIONE VERSION
	4000	4	105	115,5	1664 ←

		TESTA HEAD	H47		6	3	TIPO TYPE	A		
		A	97,25		4	2,5				
	FIN419PN		E	86		23	4		G	115,5
	0.078.1236.0/10		F	35						H
105	0.381.0060.6	FIN3102PC00	0.338.0052.6/10	FIN2320RS00	0.A13.0355.0 ≡ 0.B13.0355.0			FIN1991SL00		I
105,5		FIN3102PC05	0.338.0053.6/10	FIN2320RS05		L	125,5			
106				FIN2320RS10						

		Nr.							ADATTABILE A: SUITABLE FOR:	
---	---	------------	---	---	---	---	---	--	--------------------------------	---

CR	RP	4	63,50	67,22	29,00			STD - 025 - 050 075 - 100	0.065.1225.0 + 0.065.1225.0	FIN478CR STD
----	----	---	-------	-------	-------	--	--	------------------------------	--------------------------------	--------------

MB	RP	5	70,00	74,02	26,25			STD - 025 - 050 075 - 100	0.065.1215.0 + 0.065.1216.0	FIN279MB STD
----	----	---	-------	-------	-------	--	--	------------------------------	--------------------------------	--------------





--	--	--	--	--	--	--	--	--	--	--



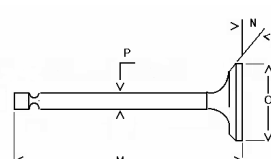

--	--	--	--	--	--	--	--	--	--	--

PB	BM	4	35,00	39,02	34,65			SEMIF.	2.1559.114.0/10	FIN110PB
----	----	---	-------	-------	-------	--	--	--------	-----------------	----------

TWS	AL	2	82,25	100,00	2,36			STD - 010 - 020	0.065.1218.0 + 0.065.1218.0	FIN167TWS STD
-----	----	---	-------	--------	------	--	--	-----------------	--------------------------------	---------------

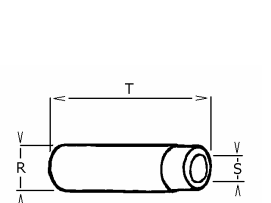
--	--	--	--	--	--	--	--	--	--	--

	IN EX		Nr.	O	P	M	N		ADATTABILE A: SUITABLE FOR:				
	IN		FR	4	44	9	131		30°		A1	0.010.6017.0	FINA6041
	EX		FSN	4	39,5	9	130,5		45°		A1	0.010.6022.0	FINS6042

	IN EX		Nr.	R	S	T		ADATTABILE A: SUITABLE FOR:				
	IN		G	4	15,03	9,02		60		I	0.007.1779.0/10	FIN6519ASA
	IN											
	EX		G	4	15,03	9,02		60		I	0.007.1779.0/10	FIN6519ASA
EX												

Ricambi non originali per motori. Denominazioni e codici originali, sono riportati a puro titolo di riferimento.





19 - 68





rel. 905



Non original engine parts. OEMs names and part numbers are for reference purpose only.







SAME







1000.4 AT1	Cm³	CILINDRI CYLINDERS	ALESAGGIO BORE	CORSA STROKE	VERSIONE VERSION
	4000	4	105	115,5	1664 ←

		 0,5 mm	
0.087.0050.6/10		0.085.1450.0	0.085.0057.6
FIN7503CGA	FIN7503CGB	FIN6281HG	FIN3104SM

		 IN	 EX
0.065.1550.0/10	0.065.1450.0/30		
FIN5010CO	FIN3208CB		

Nr.	ENGINE KIT	
1		FIN1991SL00
1		FIN3102PC00
1		FIN3104SM
0.381.0065.A/B		FIN8226KIT

 LV	 LD					
2.1529.073.0	2.1529.072.0			2.4249.131.0	2.4419.340.0	0.009.4687.0
FIN2888RT	FIN2889RT			FIN8323NF	FIN8230OF	FIN8615FE

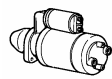
						
2.4519.310.0	2.4619.140.0	0.010.2631.2	2.4729.170.0/10			
FIN922FP	FIN1716JP	FIN1705E	FIN1725NO			

1	Guarnizione testa 0,7 mm	Head Gaket 0,7 mm	0.085.1451.0	FIN6282HG
2	Guarnizione testa 0,8 mm	Head Gaket 0,8 mm	0.085.1453.0	FIN6283HG
3	Guarnizione testa 1,0 mm	Head Gaket 1,0 mm	0.085.1452.0	FIN6284HG
4	OR per canna (117,07X3,53)	Liner O ring (117,07X3,53)	2.1539.130.0/10	FIN1098OR
5	Pompa olio	Oil pump	0.010.5441.4/10	FIN047OP
6	Cartuccia Filtro Combustibile	Fuel Filter Cartrige	2.4319.060.1	FIN8605FE
7	Massa filtrante 8"	Filtering element 8"	2.4249.130.7	FIN8322NF
8	Massa filtrante 8"	Filtering element 8"	2.4249.310.4	FIN8112NF
9				
10				
11				
12				
13				
14				
15				

Ricambi non originali per motori. Denominazioni e codici originali, sono riportati a puro titolo di riferimento.



20 - 68







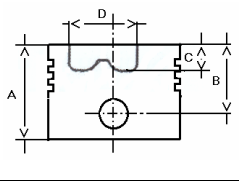

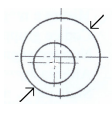
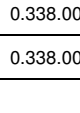
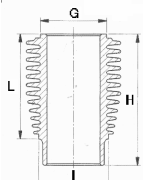
rel. 905

Non original engine parts. OEMs names and part numbers are for reference purpose only.

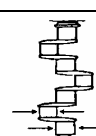
SAME

1000.4 AT1	Cm³	CILINDRI CYLINDERS	ALESAGGIO BORE	CORSA STROKE	VERSIONE VERSION
	4000	4	105	115,5	1665 → 5645

		TESTA HEAD	H47		6	3	TIPO TYPE	A	
		A	97,25		4	2,5			
	FIN419PN	E	86		23	4		G	115,5
	0.078.1236.0/10		F		35	0.338.0052.6/10		FIN2320RS00	H
	105	0.381.0060.6	FIN3102PC00					I	113
	105,5		FIN3102PC05	0.338.0053.6/10	FIN2320RS05			L	125,5
	106				FIN2320RS10			0.A13.0355.0 ≡ 0.B13.0355.0	
								FIN1991SL00	

		Nr.						ADATTABILE A: SUITABLE FOR:	
---	---	------------	---	---	---	---	---	--------------------------------	---

CR	RP	4	63,50	67,22	29,00		STD - 025 - 050 075 - 100	0.065.1225.0 + 0.065.1225.0	FIN478CR STD
----	----	---	-------	-------	-------	--	------------------------------	--------------------------------	--------------

MB	RP	5	70,00	74,02	26,25		STD - 025 - 050 075 - 100	0.065.1215.0 + 0.065.1216.0	FIN279MB STD
----	----	---	-------	-------	-------	--	------------------------------	--------------------------------	--------------





--	--	--	--	--	--	--	--	--	--



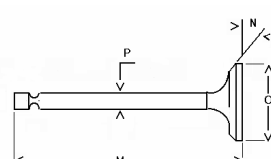

--	--	--	--	--	--	--	--	--	--

PB	BM	4	35,00	39,02	34,65		SEMIF.	2.1559.114.0/10	FIN110PB
----	----	---	-------	-------	-------	--	--------	-----------------	----------

TWS	AL	2	82,25	100,00	2,36		STD - 010 - 020	0.065.1218.0 + 0.065.1218.0	FIN167TWS STD
-----	----	---	-------	--------	------	--	-----------------	--------------------------------	---------------

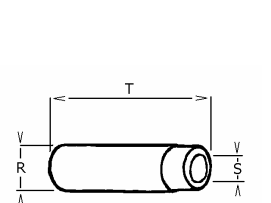
--	--	--	--	--	--	--	--	--	--

	IN EX		Nr.	O	P	M	N		ADATTABILE A: SUITABLE FOR:			
	IN		FR	4	44	9	131		30°	A1	0.010.6017.0	FINA6041
	EX		FSN	4	39,5	9	130,5		45°	A1	0.010.6022.0	FINS6042

	IN EX		Nr.	R	S	T		ADATTABILE A: SUITABLE FOR:			
	IN		G	4	15,03	9,02		60	I	0.007.1779.0/10	FIN6519ASA
	IN										
	EX		G	4	15,03	9,02		60	I	0.007.1779.0/10	FIN6519ASA
EX											

Ricambi non originali per motori. Denominazioni e codici originali, sono riportati a puro titolo di riferimento.





21 - 68





rel. 905



Non original engine parts. OEMs names and part numbers are for reference purpose only.







SAME







1000.4 AT1	Cm³	CILINDRI CYLINDERS	ALESAGGIO BORE	CORSA STROKE	VERSIONE VERSION
	4000	4	105	115,5	1665 → 5645

		 0,5 mm	
0.087.0050.6/10		0.085.1450.0	0.085.0057.6
FIN7503CGA	FIN7503CGB	FIN6281HG	FIN3104SM

		 IN	 EX
0.065.1550.0/10	0.065.1450.0/30		
FIN5010CO	FIN3208CB		

Nr.	ENGINE KIT	
1		FIN1991SL00
1		FIN3102PC00
1		FIN3104SM
0.381.0065.A/B		FIN8226KIT

 LV	 LD					
2.1529.073.0	2.1529.072.0			2.4249.131.0	2.4419.340.0	0.009.4687.0
FIN2888RT	FIN2889RT			FIN8323NF	FIN8230OF	FIN8615FE

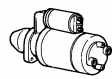
						
2.4519.310.0	2.4619.030.0/30	2.4619.030.1	2.4729.170.0/10			
FIN922FP	FIN1666JP	FIN1695E	FIN1725NO			

1	Guarnizione testa 0,7 mm	Head Gaket 0,7 mm	0.085.1451.0	FIN6282HG
2	Guarnizione testa 0,8 mm	Head Gaket 0,8 mm	0.085.1453.0	FIN6283HG
3	Guarnizione testa 1,0 mm	Head Gaket 1,0 mm	0.085.1452.0	FIN6284HG
4	OR per canna (117,07X3,53)	Liner O ring (117,07X3,53)	2.1539.130.0/10	FIN1098OR
5	Pompa olio	Oil pump	0.010.5441.4/10	FIN047OP
6	Cartuccia Filtro Combustibile	Fuel Filter Cartrige	2.4319.060.1	FIN8605FE
7	Massa filtrante 8"	Filtering element 8"	2.4249.130.7	FIN8322NF
8	Massa filtrante 8"	Filtering element 8"	2.4249.310.4	FIN8112NF
9				
10				
11				
12				
13				
14				
15				

Ricambi non originali per motori. Denominazioni e codici originali, sono riportati a puro titolo di riferimento.



22 - 68







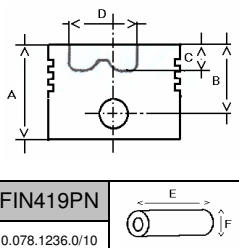

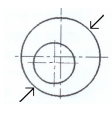
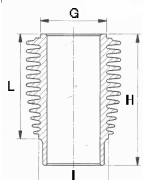
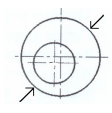
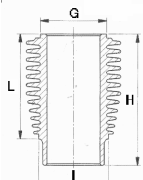
rel. 905

Non original engine parts. OEMs names and part numbers are for reference purpose only.

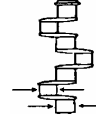
SAME

1000.4 AT2	Cm³	CILINDRI CYLINDERS	ALESAGGIO BORE	CORSA STROKE	VERSIONE VERSION
	4000	4	105	115,5	4974 ←

		TESTA HEAD	H22		6	3	TIPO TYPE	A		
		A	97,25		4	2,5				
	FIN419PN		E	86		23	4		G	115,5
	0.078.1236.0/10		F	35		0.338.0052.6/10	FIN2320RS00		H	194,5
	105	0.338.0060.6/20	FIN2404PC00		0.338.0053.6/10	FIN2320RS05	I	113	L	125,5
	105,5	0.338.0061.6/20	FIN2404PC05			FIN2320RS10	0.A13.0355.0 ≡ 0.B13.0355.0		FIN1991SL00	
	106									

		Nr.						ADATTABILE A: SUITABLE FOR:	
---	---	------------	---	---	---	---	---	--------------------------------	---

CR	RP	4	63,50	67,22	29,00		STD - 025 - 050 075 - 100	0.065.1225.0 + 0.065.1225.0	FIN478CR STD
----	----	---	-------	-------	-------	--	------------------------------	--------------------------------	--------------

MB	RP	5	70,00	74,02	26,25		STD - 025 - 050 075 - 100	0.065.1215.0 + 0.065.1216.0	FIN279MB STD
----	----	---	-------	-------	-------	--	------------------------------	--------------------------------	--------------





--	--	--	--	--	--	--	--	--	--



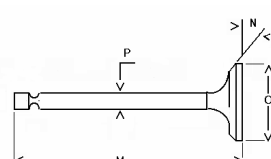

--	--	--	--	--	--	--	--	--	--

PB	BM	4	35,00	39,02	34,65		SEMIF.	2.1559.114.0/10	FIN110PB
----	----	---	-------	-------	-------	--	--------	-----------------	----------

TWS	AL	2	82,25	100,00	2,36		STD - 010 - 020	0.065.1218.0 + 0.065.1218.0	FIN167TWS STD
-----	----	---	-------	--------	------	--	-----------------	--------------------------------	---------------

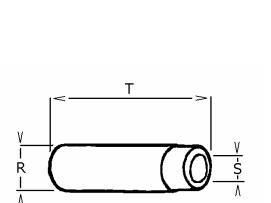
--	--	--	--	--	--	--	--	--	--

	IN EX		Nr.	O	P	M	N		ADATTABILE A: SUITABLE FOR:			
	IN		FR	4	44	9	131		30°	A1	0.010.6017.0	FINA6041
	EX		FSN	4	39,5	9	130,5		45°	A1	0.010.6022.0	FINS6042

	IN EX		Nr.	R	S	T		ADATTABILE A: SUITABLE FOR:				
	IN		G	4	15,03	9,02		60	I	0.007.1779.0/10	FIN6519ASA	
	IN											
	EX		G	4	15,03	9,02		60	I	0.007.1779.0/10	FIN6519ASA	
EX												

Ricambi non originali per motori. Denominazioni e codici originali, sono riportati a puro titolo di riferimento.





23 - 68





rel. 905



Non original engine parts. OEMs names and part numbers are for reference purpose only.







SAME







1000.4 AT2	Cm³	CILINDRI CYLINDERS	ALESAGGIO BORE	CORSA STROKE	VERSIONE VERSION
	4000	4	105	115,5	4974 ←

		 0,5 mm	
0.087.0050.6/10		0.085.1450.0	0.085.0057.6
FIN7503CGA	FIN7503CGB	FIN6281HG	FIN3104SM

		 IN	 EX
0.065.1550.0/10	0.065.1450.0/30		
FIN5010CO	FIN3208CB		

Nr.	ENGINE KIT	
1		FIN1991SL00
1		FIN2404PC00
1		FIN3104SM
0.338.0065.A/B		FIN2051KIT

 LV	 LD					
2.1529.073.0	2.1529.072.0			2.4249.131.0	2.4419.340.0	0.009.4687.0
FIN2888RT	FIN2889RT			FIN8323NF	FIN8230OF	FIN8615FE

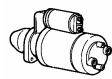
						
2.4519.310.0		0.010.2631.2	2.4729.100.0			
FIN922FP		FIN1705E	FIN161NO			

1	Guarnizione testa 0,7 mm	Head Gaket 0,7 mm	0.085.1451.0	FIN6282HG
2	Guarnizione testa 0,8 mm	Head Gaket 0,8 mm	0.085.1453.0	FIN6283HG
3	Guarnizione testa 1,0 mm	Head Gaket 1,0 mm	0.085.1452.0	FIN6284HG
4	OR per canna (117,07X3,53)	Liner O ring (117,07X3,53)	2.1539.130.0/10	FIN1098OR
5	Pompa olio	Oil pump	0.010.5441.4/10	FIN047OP
6	Massa filtrante 8"	Filtering element 8"	2.4249.130.7	FIN8322NF
7				
8				
9				
10				
11				
12				
13				
14				
15				

Ricambi non originali per motori. Denominazioni e codici originali, sono riportati a puro titolo di riferimento.



24 - 68





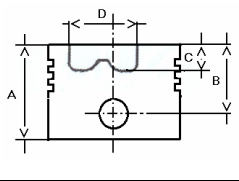

rel. 905

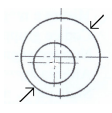
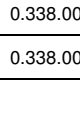
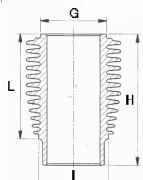
Non original engine parts. OEMs names and part numbers are for reference purpose only.

SAME

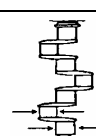
1000.4 AT2	Cm³	CILINDRI CYLINDERS	ALESAGGIO BORE	CORSA STROKE	VERSIONE VERSION
	4000	4	105	115,5	4975 →

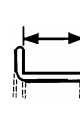
		TESTA HEAD	H47		6	3	TIPO TYPE	A	
		A	97,25		4	2,5			
	FIN419PN	E	86		23	4		G	115,5
	0.078.1236.0/10		F		35	0.338.0052.6/10		FIN2320RS00	H
	105	0.381.0060.6	FIN3102PC00					I	113
	105,5		FIN3102PC05		0.338.0053.6/10	FIN2320RS05		L	125,5
	106					FIN2320RS10		0.A13.0355.0 ≡ 0.B13.0355.0	
								FIN1991SL00	

		Nr.						ADATTABILE A: SUITABLE FOR:	
---	---	------------	---	---	---	---	---	--------------------------------	---

CR	RP	4	63,50	67,22	29,00		STD - 025 - 050 075 - 100	0.065.1225.0 + 0.065.1225.0	FIN478CR STD
----	----	---	-------	-------	-------	--	------------------------------	--------------------------------	--------------

MB	RP	5	70,00	74,02	26,25		STD - 025 - 050 075 - 100	0.065.1215.0 + 0.065.1216.0	FIN279MB STD
----	----	---	-------	-------	-------	--	------------------------------	--------------------------------	--------------





--	--	--	--	--	--	--	--	--	--



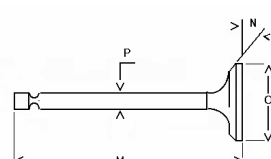

--	--	--	--	--	--	--	--	--	--

PB	BM	4	35,00	39,02	34,65		SEMIF.	2.1559.114.0/10	FIN110PB
----	----	---	-------	-------	-------	--	--------	-----------------	----------

TWS	AL	2	82,25	100,00	2,36		STD - 010 - 020	0.065.1218.0 + 0.065.1218.0	FIN167TWS STD
-----	----	---	-------	--------	------	--	-----------------	--------------------------------	---------------

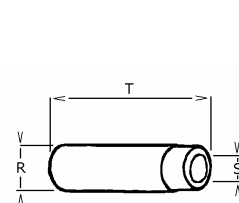
--	--	--	--	--	--	--	--	--	--

	IN EX		Nr.	O	P	M	N		ADATTABILE A: SUITABLE FOR:			
	IN		FR	4	44	9	131		30°	A1	0.010.6017.0	FINA6041
	EX		FSN	4	39,5	9	130,5		45°	A1	0.010.6022.0	FINS6042

	IN EX		Nr.	R	S	T		ADATTABILE A: SUITABLE FOR:			
	IN		G	4	15,03	9,02		60	I	0.007.1779.0/10	FIN6519ASA
	EX		G	4	15,03	9,02		60	I	0.007.1779.0/10	FIN6519ASA
	EX										

Ricambi non originali per motori. Denominazioni e codici originali, sono riportati a puro titolo di riferimento.





25 - 68





rel. 905



Non original engine parts. OEMs names and part numbers are for reference purpose only.







SAME







1000.4 AT2	Cm³	CILINDRI CYLINDERS	ALESAGGIO BORE	CORSA STROKE	VERSIONE VERSION
	4000	4	105	115,5	4975 →

		 0,5 mm	
0.087.0050.6/10		0.085.1450.0	0.085.0057.6
FIN7503CGA	FIN7503CGB	FIN6281HG	FIN3104SM

		 IN	 EX
0.065.1550.0/10	0.065.1450.0/30		
FIN5010CO	FIN3208CB		

Nr.	ENGINE KIT	
1		FIN1991SL00
1		FIN3102PC00
1		FIN3104SM
0.381.0065.A/B		FIN8226KIT

 LV	 LD					
2.1529.073.0	2.1529.072.0			2.4249.131.0	2.4419.340.0	0.009.4687.0
FIN2888RT	FIN2889RT			FIN8323NF	FIN8230OF	FIN8615FE

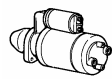
						
2.4519.310.0	2.4619.030.0/30	2.4619.030.1	2.4729.100.0			
FIN922FP	FIN1666JP	FIN1695E	FIN161NO			

1	Guarnizione testa 0,7 mm	Head Gaket 0,7 mm	0.085.1451.0	FIN6282HG
2	Guarnizione testa 0,8 mm	Head Gaket 0,8 mm	0.085.1453.0	FIN6283HG
3	Guarnizione testa 1,0 mm	Head Gaket 1,0 mm	0.085.1452.0	FIN6284HG
4	OR per canna (117,07X3,53)	Liner O ring (117,07X3,53)	2.1539.130.0/10	FIN1098OR
5	Pompa olio	Oil pump	0.010.5441.4/10	FIN047OP
6	Massa filtrante 8"	Filtering element 8"	2.4249.130.7	FIN8322NF
7				
8				
9				
10				
11				
12				
13				
14				
15				

Ricambi non originali per motori. Denominazioni e codici originali, sono riportati a puro titolo di riferimento.

26 - 68

rel. 905

Non original engine parts. OEMs names and part numbers are for reference purpose only.

SAME

1000.4 ATG	Cm³	CILINDRI CYLINDERS	ALESAGGIO BORE	CORSA STROKE	VERSIONE VERSION
	4000	4	105	115,5	18772 ←

		TESTA HEAD	H22		6	3	TIPO TYPE	A	
		A	97,25		4	2,5			G
	FIN419PN	E	86	0.338.0052.6/10	23	4			H
	0.078.1236.0/10	F	35					0.338.0053.6/10	FIN2320RS05
105	0.338.0060.6/20	FIN2404PC00		FIN2320RS10		0.007.0762.0/40 ≡ 0.007.0762.0/50		L	125,5
105,5	0.338.0061.6/20	FIN2404PC05						FIN1991SL00	
106									

		Nr.						ADATTABILE A: SUITABLE FOR:	
--	--	------------	--	--	--	--	--	--	--

CR	RP	4	63,50	67,22	29,00		STD - 025 - 050 075 - 100	0.065.1225.0 + 0.065.1225.0	FIN478CR STD
----	----	---	-------	-------	-------	--	------------------------------	--------------------------------	--------------

MB	RP	5	70,00	74,02	26,25		STD - 025 - 050 075 - 100	0.065.1215.0 + 0.065.1216.0	FIN279MB STD
----	----	---	-------	-------	-------	--	------------------------------	--------------------------------	--------------

--	--	--	--	--	--	--	--	--	--

--	--	--	--	--	--	--	--	--	--

PB	BM	4	35,00	39,02	34,65		SEMIF.	2.1559.114.0/10	FIN110PB
----	----	---	-------	-------	-------	--	--------	-----------------	----------

TWS	AL	2	82,25	100,00	2,36		STD - 010 - 020	0.065.1218.0 + 0.065.1218.0	FIN167TWS STD
-----	----	---	-------	--------	------	--	-----------------	--------------------------------	---------------

--	--	--	--	--	--	--	--	--	--

	IN EX		Nr.	O	P	M	N		ADATTABILE A: SUITABLE FOR:	
	IN	FR	4	44	9	131	30°	A1	0.010.6017.0	FINA6041
	EX	FSN	4	39,5	9	130,5	45°	A1	0.010.6022.0	FINS6042

	IN EX		Nr.	R	S	T		ADATTABILE A: SUITABLE FOR:	
	IN	G	4	15,03	9,02	60	I	0.007.1779.0/10	FIN6519ASA
	IN								
	EX	G	4	15,03	9,02	60	I	0.007.1779.0/10	FIN6519ASA
EX									

Ricambi non originali per motori. Denominazioni e codici originali, sono riportati a puro titolo di riferimento.





27 - 68





rel. 905



Non original engine parts. OEMs names and part numbers are for reference purpose only.







SAME







1000.4 ATG	Cm³	CILINDRI CYLINDERS	ALESAGGIO BORE	CORSA STROKE	VERSIONE VERSION
	4000	4	105	115,5	18772 ←

		 0,5 mm	
0.087.0050.6/10		0.085.1450.0	0.085.0057.6
FIN7503CGA	FIN7503CGB	FIN6281HG	FIN3104SM

		 IN	 EX
0.065.1571.0	0.065.1450.0/30		
FIN5009CO	FIN3208CB		

Nr.	ENGINE KIT	
1		FIN1991SL00
1		FIN2404PC00
1		FIN3104SM
0.338.0065.6/20		FIN2051KIT

 LV	 LD					
2.1529.073.0	2.1529.141.0	2.4249.130.0/10	2.4239.100.0	0.010.3283.1	2.4419.340.0	2.4319.060.1
FIN2888RT	FIN2889RT	FIN8244AF	FIN8225PF	FIN8124NF	FIN8230OF	FIN8605FE

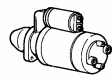
					 26V-35A	 14V-3KW ISKRA
2.4519.300.0		2.4619.030.1	2.4729.100.0	2.4619.010.2	2.9439.260.0/10	2.9619.180.0/10
FIN919FP		FIN1695E	FIN161NO	FIN1690DV	FIN2305VA	FIN201TL

1	Guarnizione testa 0,7 mm	Head Gaket 0,7 mm	0.085.1451.0	FIN6282HG
2	Guarnizione testa 0,8 mm	Head Gaket 0,8 mm	0.085.1453.0	FIN6283HG
3	Guarnizione testa 1,0 mm	Head Gaket 1,0 mm	0.085.1452.0	FIN6284HG
4	OR per canna (117,07X3,53)	Liner O ring (117,07X3,53)	2.1539.130.0/10	FIN1098OR
5	Pompa olio	Oil pump	0.010.5441.4/10	FIN047OP
6	Kit revisione pompa alimentazione	Fuel pump repairing kit	2.4519.269.0	FIN2919KFP
7	Filtro Aria 8"	Air cleaner 8"	0.87335.51.0	FIN8035AF
8	Filtro Aria 6"	Air cleaner 6"	2.4249.250.0/10	FIN8201AF
9	Filtro Aria 6"	Air cleaner 6"	0.87334.51.0	FIN8030AF
10	Massa filtrante 6"	Filtering element 6"	0.010.3284.2	FIN8145NF
11	Motorino d'avviamento 28V-3,2KW ISKRA	Starter engine 28V-3,2KW ISKRA	2.9619.120.0/10	FIN1865TL
12				
13				
14				
15				

Ricambi non originali per motori. Denominazioni e codici originali, sono riportati a puro titolo di riferimento.





28 - 68





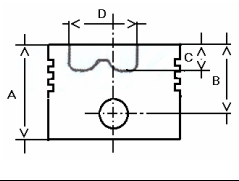

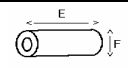

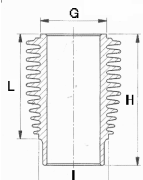
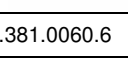
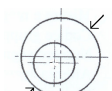
rel. 905

Non original engine parts. OEMs names and part numbers are for reference purpose only.

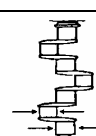
SAME

1000.4 ATG	Cm³	CILINDRI CYLINDERS	ALESAGGIO BORE	CORSA STROKE	VERSIONE VERSION
	4000	4	105	115,5	18773 → 21296

		TESTA HEAD	H47		6	3	TIPO TYPE	A	
		A	97,25		4	2,5			
FIN419PN 0.078.1236.0/10		E	86		23	4		G	115,5
		F	35			0.338.0052.6/10		FIN2320RS00	H
	105	0.381.0060.6	FIN3102PC00	0.007.0762.0/40 ≡ 0.007.0762.0/50			FIN1991SL00		I
	105,5		FIN3102PC05		L	125,5			
	106				0.338.0053.6/10	FIN2320RS05 FIN2320RS10			

		Nr.						ADATTABILE A: SUITABLE FOR:	
---	---	------------	---	---	---	---	---	--------------------------------	---

CR	RP	4	63,50	67,22	29,00		STD - 025 - 050 075 - 100	0.065.1225.0 + 0.065.1225.0	FIN478CR STD
----	----	---	-------	-------	-------	--	------------------------------	--------------------------------	--------------

MB	RP	5	70,00	74,02	26,25		STD - 025 - 050 075 - 100	0.065.1215.0 + 0.065.1216.0	FIN279MB STD
----	----	---	-------	-------	-------	--	------------------------------	--------------------------------	--------------





--	--	--	--	--	--	--	--	--	--



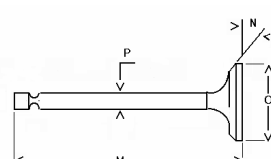

--	--	--	--	--	--	--	--	--	--

PB	BM	4	35,00	39,02	34,65		SEMIF.	2.1559.114.0/10	FIN110PB
----	----	---	-------	-------	-------	--	--------	-----------------	----------

TWS	AL	2	82,25	100,00	2,36		STD - 010 - 020	0.065.1218.0 + 0.065.1218.0	FIN167TWS STD
-----	----	---	-------	--------	------	--	-----------------	--------------------------------	---------------

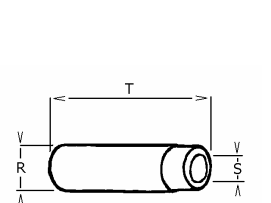
--	--	--	--	--	--	--	--	--	--

	IN EX		Nr.	O	P	M	N		ADATTABILE A: SUITABLE FOR:			
	IN		FR	4	44	9	131		30°	A1	0.010.6017.0	FINA6041
	EX		FSN	4	39,5	9	130,5		45°	A1	0.010.6022.0	FINS6042

	IN EX		Nr.	R	S	T		ADATTABILE A: SUITABLE FOR:			
	IN		G	4	15,03	9,02		60	I	0.007.1779.0/10	FIN6519ASA
	IN										
	EX		G	4	15,03	9,02		60	I	0.007.1779.0/10	FIN6519ASA
EX											

Ricambi non originali per motori. Denominazioni e codici originali, sono riportati a puro titolo di riferimento.





29 - 68





rel. 905



Non original engine parts. OEMs names and part numbers are for reference purpose only.







SAME







1000.4 ATG	Cm³	CILINDRI CYLINDERS	ALESAGGIO BORE	CORSA STROKE	VERSIONE VERSION
	4000	4	105	115,5	18773 → 21296

		 0,5 mm	
0.087.0050.6/10		0.085.1450.0	0.085.0057.6
FIN7503CGA	FIN7503CGB	FIN6281HG	FIN3104SM

		 IN	 EX
0.065.1571.0	0.065.1450.0/30		
FIN5009CO	FIN3208CB		

Nr.	ENGINE KIT	
1		FIN1991SL00
1		FIN3102PC00
1		FIN3104SM
0.381.0065.A/B		FIN8226KIT

 LV	 LD					
2.1529.073.0	2.1529.141.0	2.4249.130.0/10	2.4239.100.0	0.010.3283.1	2.4419.340.0	2.4319.060.1
FIN2888RT	FIN2889RT	FIN8244AF	FIN8225PF	FIN8124NF	FIN8230OF	FIN8605FE

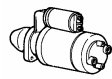
					 26V-35A	 14V-3KW ISKRA
2.4519.300.0		2.4619.030.1	2.4729.100.0	2.4619.010.2	2.9439.260.0/10	2.9619.180.0/10
FIN919FP		FIN1695E	FIN161NO	FIN1690DV	FIN2305VA	FIN201TL

1	Guarnizione testa 0,7 mm	Head Gaket 0,7 mm	0.085.1451.0	FIN6282HG
2	Guarnizione testa 0,8 mm	Head Gaket 0,8 mm	0.085.1453.0	FIN6283HG
3	Guarnizione testa 1,0 mm	Head Gaket 1,0 mm	0.085.1452.0	FIN6284HG
4	OR per canna (117,07X3,53)	Liner O ring (117,07X3,53)	2.1539.130.0/10	FIN1098OR
5	Pompa olio	Oil pump	0.010.5441.4/10	FIN047OP
6	Kit revisione pompa alimentazione	Fuel pump repairing kit	2.4519.269.0	FIN2919KFP
7	Filtro Aria 8"	Air cleaner 8"	0.87335.51.0	FIN8035AF
8	Filtro Aria 6"	Air cleaner 6"	2.4249.250.0/10	FIN8201AF
9	Filtro Aria 6"	Air cleaner 6"	0.87334.51.0	FIN8030AF
10	Massa filtrante 6"	Filtering element 6"	0.010.3284.2	FIN8145NF
11	Motorino d'avviamento 28V-3,2KW ISKRA	Starter engine 28V-3,2KW ISKRA	2.9619.120.0/10	FIN1865TL
12				
13				
14				
15				

Ricambi non originali per motori. Denominazioni e codici originali, sono riportati a puro titolo di riferimento.





30 - 68





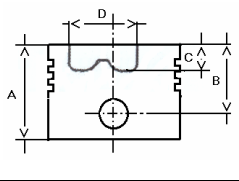

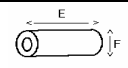

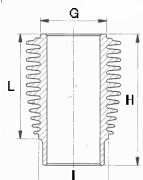
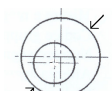
rel. 905

Non original engine parts. OEMs names and part numbers are for reference purpose only.

SAME

1000.4 ATG	Cm³	CILINDRI CYLINDERS	ALESAGGIO BORE	CORSA STROKE	VERSIONE VERSION
	4000	4	105	115,5	21297 →

		TESTA HEAD	H47		6	3	TIPO TYPE	A	
		A	97,25		4	2,5			
FIN419PN 0.078.1236.0/10		B	57,25		23	4		G	115,5
		C	20,85		E	86		0.338.0052.6/10 FIN2320RS00 0.338.0053.6/10 FIN2320RS05 FIN2320RS10	H
	105	0.381.0060.6	FIN3102PC00				I		113
	105,5		FIN3102PC05				L	125,5	
	106						0.A13.0355.0 ≡ 0.B13.0355.0 FIN1991SL00		

		Nr.						ADATTABILE A: SUITABLE FOR:	
---	---	------------	---	---	---	---	---	--------------------------------	---

CR	RP	4	63,50	67,22	29,00		STD - 025 - 050 075 - 100	0.065.1225.0 + 0.065.1225.0	FIN478CR STD
----	----	---	-------	-------	-------	--	------------------------------	--------------------------------	---------------------

MB	RP	5	70,00	74,02	26,25		STD - 025 - 050 075 - 100	0.065.1215.0 + 0.065.1216.0	FIN279MB STD
----	----	---	-------	-------	-------	--	------------------------------	--------------------------------	---------------------





--	--	--	--	--	--	--	--	--	--



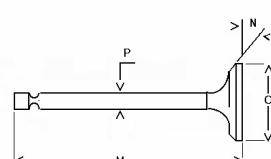

--	--	--	--	--	--	--	--	--	--

PB	BM	4	35,00	39,02	34,65		SEMIF.	2.1559.114.0/10	FIN110PB
----	----	---	-------	-------	-------	--	--------	-----------------	-----------------

TWS	AL	2	82,25	100,00	2,36		STD - 010 - 020	0.065.1218.0 + 0.065.1218.0	FIN167TWS STD
-----	----	---	-------	--------	------	--	-----------------	--------------------------------	----------------------

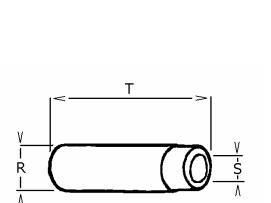
--	--	--	--	--	--	--	--	--	--

	IN EX		Nr.	O	P	M	N		ADATTABILE A: SUITABLE FOR:			
	IN		FR	4	44	9	131		30°	A1	0.010.6017.0	FINA6041
	EX		FSN	4	39,5	9	130,5		45°	A1	0.010.6022.0	FINS6042

	IN EX		Nr.	R	S	T		ADATTABILE A: SUITABLE FOR:			
	IN		G	4	15,03	9,02		60	I	0.007.1779.0/10	FIN6519ASA
	EX		G	4	15,03	9,02		60	I	0.007.1779.0/10	FIN6519ASA
	EX										

Ricambi non originali per motori. Denominazioni e codici originali, sono riportati a puro titolo di riferimento.

31 - 68

rel. 905

Non original engine parts. OEMs names and part numbers are for reference purpose only.

SAME

1000.4 ATG	Cm³	CILINDRI CYLINDERS	ALESAGGIO BORE	CORSA STROKE	VERSIONE VERSION
	4000	4	105	115,5	21297 →

0.087.0050.6/10		0.085.1450.0	0.085.0057.6
FIN7503CGA	FIN7503CGB	FIN6281HG	FIN3104SM

0.065.1571.0	0.065.1450.0/30		
FIN5009CO	FIN3208CB		

Nr.	ENGINE KIT	
1		FIN1991SL00
1		FIN3102PC00
1		FIN3104SM
0.381.0065.A/B		FIN8226KIT

2.1529.073.0	2.1529.141.0	2.4249.130.0/10	2.4239.100.0	0.010.3283.1	2.4419.340.0	2.4319.060.1
FIN2888RT	FIN2889RT	FIN8244AF	FIN8225PF	FIN8124NF	FIN8230OF	FIN8605FE

2.4519.300.0		2.4619.030.1	2.4729.170.0/10	2.4619.010.2	2.9439.260.0/10	2.9619.180.0/10
FIN919FP		FIN1695E	FIN1725NO	FIN1690DV	FIN2305VA	FIN201TL

1	Guarnizione testa 0,7 mm	Head Gaket 0,7 mm	0.085.1451.0	FIN6282HG
2	Guarnizione testa 0,8 mm	Head Gaket 0,8 mm	0.085.1453.0	FIN6283HG
3	Guarnizione testa 1,0 mm	Head Gaket 1,0 mm	0.085.1452.0	FIN6284HG
4	OR per canna (117,07X3,53)	Liner O ring (117,07X3,53)	2.1539.130.0/10	FIN1098OR
5	Pompa olio	Oil pump	0.010.5441.4/10	FIN047OP
6	Kit revisione pompa alimentazione	Fuel pump repairing kit	2.4519.269.0	FIN2919KFP
7	Filtro Aria 8"	Air cleaner 8"	0.87335.51.0	FIN8035AF
8	Filtro Aria 6"	Air cleaner 6"	2.4249.250.0/10	FIN8201AF
9	Filtro Aria 6"	Air cleaner 6"	0.87334.51.0	FIN8030AF
10	Massa filtrante 6"	Filtering element 6"	0.010.3284.2	FIN8145NF
11	Motorino d'avviamento 28V-3,2KW ISKRA	Starter engine 28V-3,2KW ISKRA	2.9619.120.0/10	FIN1865TL
12				
13				
14				
15				

Ricambi non originali per motori. Denominazioni e codici originali, sono riportati a puro titolo di riferimento.





32 - 68





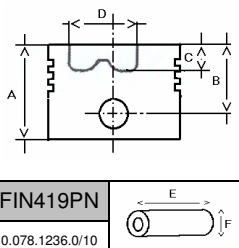

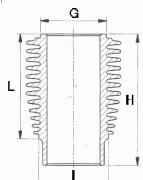
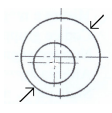

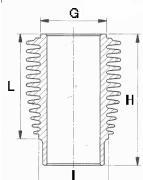
rel. 905

Non original engine parts. OEMs names and part numbers are for reference purpose only.

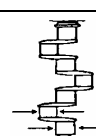
SAME

1000.6 AT	Cm³	CILINDRI CYLINDERS	ALESAGGIO BORE	CORSA STROKE	VERSIONE VERSION
	6000	6	105	115,5	4772 ←

		TESTA HEAD	H22		6	3	TIPO TYPE	A	
					4	2,5			
	FIN419PN 0.078.1236.0/10		E 86 F 35		23	4		G	115,5
					105	0.338.0060.6/20		FIN2404PC00	0.338.0052.6/10
	105,5	0.338.0061.6/20	FIN2404PC05	0.338.0053.6/10	FIN2320RS05	I	113		
	106				FIN2320RS10	L	125,5		
							0.007.0762.0/40 ≡ 0.007.0762.0/50	FIN1991SL00	

		Nr.						ADATTABILE A: SUITABLE FOR:	
---	---	------------	---	---	---	---	---	--------------------------------	---

CR	RP	6	63,50	67,22	29,00		STD - 025 - 050 075 - 100	0.065.1225.0 + 0.065.1225.0	FIN478CR STD
----	----	---	-------	-------	-------	--	------------------------------	--------------------------------	--------------

MB	RP	7	70,00	74,02	26,25		STD - 025 - 050 075 - 100	0.065.1215.0 + 0.065.1216.0	FIN279MB STD
----	----	---	-------	-------	-------	--	------------------------------	--------------------------------	--------------





--	--	--	--	--	--	--	--	--	--



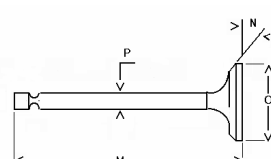

--	--	--	--	--	--	--	--	--	--

PB	BM	6	35,00	39,02	34,65		SEMIF.	2.1559.114.0/10	FIN110PB
----	----	---	-------	-------	-------	--	--------	-----------------	----------

TWS	AL	2	82,25	100,00	2,36		STD - 010 - 020	0.065.1218.0 + 0.065.1218.0	FIN167TWS STD
-----	----	---	-------	--------	------	--	-----------------	--------------------------------	---------------

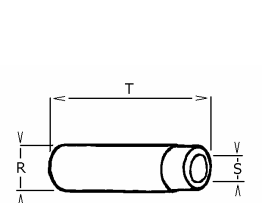
--	--	--	--	--	--	--	--	--	--

	IN EX		Nr.	O	P	M	N		ADATTABILE A: SUITABLE FOR:								
	IN								FR	6	44	9	131	30°	A1	0.010.6017.0	FINA6041
	EX								FSN	6	39,5	9	130,5	45°	A1	0.010.6022.0	FINS6042

	IN EX		Nr.	R	S	T		ADATTABILE A: SUITABLE FOR:							
	IN							G	6	15,03	9,02	60	I	0.007.1779.0/10	FIN6519ASA
	EX							G	6	15,03	9,02	60	I	0.007.1779.0/10	FIN6519ASA
	EX														

Ricambi non originali per motori. Denominazioni e codici originali, sono riportati a puro titolo di riferimento.





33 - 68





rel. 905



Non original engine parts. OEMs names and part numbers are for reference purpose only.







SAME







1000.6 AT	Cm³	CILINDRI CYLINDERS	ALESAGGIO BORE	CORSA STROKE	VERSIONE VERSION
	6000	6	105	115,5	4772 ←

		 0,5 mm	
0.336.0050.6/10		0.085.1450.0	0.085.0057.6
FIN7507CGA	FIN7507CGB	FIN6281HG	FIN3104SM

		 IN	 EX
0.007.0849.0/10	0.009.3877.0/10		
FIN5005CO	FIN3211CB		

Nr.	ENGINE KIT	
1		FIN1991SL00
1		FIN2404PC00
1		FIN3104SM
0.338.0065.6/20		FIN2051KIT

 LV	 LD					
2.1529.073.0	2.1529.141.0	0.87335.51.0		0.010.3283.1	2.4419.340.0	2.4319.130.1
FIN2888RT	FIN2889RT	FIN8035AF		FIN8124NF	FIN8230OF	FIN8722FE

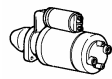
					 14V-35A	 14V-3KW ISKRA
2.4519.310.0		0.009.4303.1	2.4729.100.0	0.010.2630.0	2.9439.220.0/10	2.9619.180.0/10
FIN922FP		FIN1701E	FIN161NO	FIN1698DV	FIN2288VA	FIN201TL

1	Guarnizione testa 0,7 mm	Head Gaket 0,7 mm	0.085.1451.0	FIN6282HG
2	Guarnizione testa 0,8 mm	Head Gaket 0,8 mm	0.085.1453.0	FIN6283HG
3	Guarnizione testa 1,0 mm	Head Gaket 1,0 mm	0.085.1452.0	FIN6284HG
4	OR per canna (117,07X3,53)	Liner O ring (117,07X3,53)	2.1539.130.0/10	FIN1098OR
5	Pompa olio	Oil pump	0.010.0194.4/20	FIN048OP
6	Kit revisione pompa alimentazione	Fuel pump repairing kit	2.4519.269.0	FIN2919KFP
7	Filtro Aria 8"	Air cleaner 8"	2.4249.130.0/10	FIN8244AF
8	Filtro Aria 10"	Air cleaner 10"	2.4249.380.0	FIN8263AF
9	Filtro Aria (bagno olio)	Air cleaner (oil bath)	0.88352.50.3	FIN8271AF
10	Filtro Aria (bagno olio)	Air cleaner (oil bath)	0.88353.50.3	FIN8272AF
11	Massa filtrante 10"	Filtering element 10"	2.4249.380.1	FIN8266NF
12	Massa filtrante 10"	Filtering element 10"	2.4249.380.2	FIN8267NF
13	Alternatore 14V-65A-ISKRA	Alternator 14V-65A-ISKRA	2.9439.420.0/10	FIN2320VA
14	Alternatore	Alternator	2.9439.460.0/10	FIN2330VA
15	Alternatore 26V-35A	Alternator 26V-35A	2.9439.260.0/10	FIN2305VA

Ricambi non originali per motori. Denominazioni e codici originali, sono riportati a puro titolo di riferimento.

34 - 68

rel. 905

Non original engine parts. OEMs names and part numbers are for reference purpose only.

SAME

1000.6 AT	Cm³	CILINDRI CYLINDERS	ALESAGGIO BORE	CORSA STROKE	VERSIONE VERSION
	6000	6	105	115,5	4772 ←

16	Motorino d'avviamento 28V-3,2KW	<i>Starter engine 28V-3,2KW</i>	2.9619.120.0	FIN1865TL
17	Pompante	<i>Injection plunger</i>	0.009.4340.1	FIN1699E
18	Pompante	<i>Injection plunger</i>	2.4619.030.1	FIN1695E
19	Valvolina mandata	<i>Delivery valve</i>	2.4619.010.2	FIN1690DV
20				
21				
22				
23				
24				
25				
26				
27				
28				
29				
30				
31				
32				
33				
34				
35				
36				
37				
38				
39				
40				
41				
42				
43				
44				
45				
46				
47				
48				
49				
50				
51				
52				
53				
54				

Ricambi non originali per motori. Denominazioni e codici originali, sono riportati a puro titolo di riferimento.

34a- 68

rel. 905

Non original engine parts. OEMs names and part numbers are for reference purpose only.





SAME





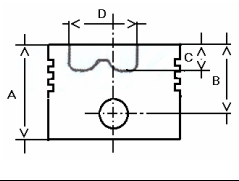

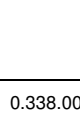
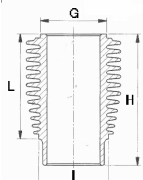
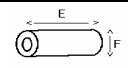

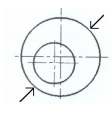
1000.6 AT	Cm ³	CILINDRI CYLINDERS	ALESAGGIO BORE	CORSA STROKE	VERSIONE VERSION
	6000	6	105	115,5	4772 ←

55				
56				
57				
58				
59				
60				
61				
62				
63				
64				
65				
66				
67				
68				
69				
70				
71				
72				
73				
74				
75				
76				
77				
78				
79				
80				
81				
82				
83				
84				
85				
86				
87				
88				
89				
90				
91				
92				
93				

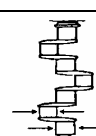
SAME

1000.6 AT	Cm³	CILINDRI CYLINDERS	ALESAGGIO BORE	CORSA STROKE	VERSIONE VERSION
	6000	6	105	115,5	4773 → 4847

		TESTA HEAD	H47		6	3	TIPO TYPE	A	
		A	97,25		4	2,5		G	115,5
FIN419PN 0.078.1236.0/10		E	86		23	4		H	194,5
		D	56						I
	105	0.381.0060.6	FIN3102PC00	0.338.0052.6/10		FIN2320RS00		0.007.0762.0/40 ≡ 0.007.0762.0/50	L
	105,5		FIN3102PC05	0.338.0053.6/10	FIN2320RS05		FIN1991SL00		
	106					FIN2320RS10			

		Nr.						ADATTABILE A: SUITABLE FOR:	
---	---	------------	---	---	---	---	---	--------------------------------	---

CR	RP	6	63,50	67,22	29,00		STD - 025 - 050 075 - 100	0.065.1225.0 + 0.065.1225.0	FIN478CR STD
----	----	---	-------	-------	-------	--	------------------------------	--------------------------------	--------------

MB	RP	7	70,00	74,02	26,25		STD - 025 - 050 075 - 100	0.065.1215.0 + 0.065.1216.0	FIN279MB STD
----	----	---	-------	-------	-------	--	------------------------------	--------------------------------	--------------





--	--	--	--	--	--	--	--	--	--



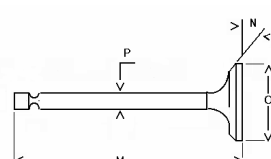

--	--	--	--	--	--	--	--	--	--

PB	BM	6	35,00	39,02	34,65		SEMIF.	2.1559.114.0/10	FIN110PB
----	----	---	-------	-------	-------	--	--------	-----------------	----------

TWS	AL	2	82,25	100,00	2,36		STD - 010 - 020	0.065.1218.0 + 0.065.1218.0	FIN167TWS STD
-----	----	---	-------	--------	------	--	-----------------	--------------------------------	---------------

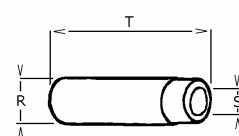
--	--	--	--	--	--	--	--	--	--

	IN EX		Nr.	O	P	M	N		ADATTABILE A: SUITABLE FOR:			
	IN		FR	6	44	9	131		30°	A1	0.010.6017.0	FINA6041
	EX		FSN	6	39,5	9	130,5		45°	A1	0.010.6022.0	FINS6042

	IN EX		Nr.	R	S	T		ADATTABILE A: SUITABLE FOR:			
	IN		G	6	15,03	9,02		60	I	0.007.1779.0/10	FIN6519ASA
	IN										
	EX		G	6	15,03	9,02		60	I	0.007.1779.0/10	FIN6519ASA
EX											

Ricambi non originali per motori. Denominazioni e codici originali, sono riportati a puro titolo di riferimento.





35 - 68





rel. 905



Non original engine parts. OEMs names and part numbers are for reference purpose only.







SAME







1000.6 AT	Cm³	CILINDRI CYLINDERS	ALESAGGIO BORE	CORSA STROKE	VERSIONE VERSION
	6000	6	105	115,5	4773 → 4847

		 0,5 mm	
0.336.0050.6/10		0.085.1450.0	0.085.0057.6
FIN7507CGA	FIN7507CGB	FIN6281HG	FIN3104SM

		 IN	 EX
0.007.0849.0/10	0.009.3877.0/10		
FIN5005CO	FIN3211CB		

Nr.	ENGINE KIT	
1		FIN1991SL00
1		FIN3102PC00
1		FIN3104SM
0.381.0065.A/B		FIN8226KIT

 LV	 LD					
2.1529.073.0	2.1529.141.0	0.87335.51.0		0.010.3283.1	2.4419.340.0	2.4319.130.1
FIN2888RT	FIN2889RT	FIN8035AF		FIN8124NF	FIN8230OF	FIN8722FE

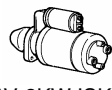
					 14V-35A	 14V-3KW ISKRA
2.4519.310.0		0.009.4303.1	2.4729.100.0	0.010.2630.0	2.9439.220.0/10	2.9619.180.0/10
FIN922FP		FIN1701E	FIN161NO	FIN1698DV	FIN2288VA	FIN201TL

1	Guarnizione testa 0,7 mm	Head Gaket 0,7 mm	0.085.1451.0	FIN6282HG
2	Guarnizione testa 0,8 mm	Head Gaket 0,8 mm	0.085.1453.0	FIN6283HG
3	Guarnizione testa 1,0 mm	Head Gaket 1,0 mm	0.085.1452.0	FIN6284HG
4	OR per canna (117,07X3,53)	Liner O ring (117,07X3,53)	2.1539.130.0/10	FIN1098OR
5	Pompa olio	Oil pump	0.010.0194.4/20	FIN048OP
6	Kit revisione pompa alimentazione	Fuel pump repairing kit	2.4519.269.0	FIN2919KFP
7	Filtro Aria 8"	Air cleaner 8"	2.4249.130.0/10	FIN8244AF
8	Filtro Aria 10"	Air cleaner 10"	2.4249.380.0	FIN8263AF
9	Filtro Aria (bagno olio)	Air cleaner (oil bath)	0.88352.50.3	FIN8271AF
10	Filtro Aria (bagno olio)	Air cleaner (oil bath)	0.88353.50.3	FIN8272AF
11	Massa filtrante 10"	Filtering element 10"	2.4249.380.1	FIN8266NF
12	Massa filtrante 10"	Filtering element 10"	2.4249.380.2	FIN8267NF
13	Alternatore 14V-65A-ISKRA	Alternator 14V-65A-ISKRA	2.9439.420.0/10	FIN2320VA
14	Alternatore	Alternator	2.9439.460.0/10	FIN2330VA
15	Alternatore 26V-35A	Alternator 26V-35A	2.9439.260.0/10	FIN2305VA

Ricambi non originali per motori. Denominazioni e codici originali, sono riportati a puro titolo di riferimento.

36 - 68

rel. 905

Non original engine parts. OEMs names and part numbers are for reference purpose only.

SAME

1000.6 AT	Cm³	CILINDRI CYLINDERS	ALESAGGIO BORE	CORSA STROKE	VERSIONE VERSION
	6000	6	105	115,5	4773 → 4847

16	Motorino d'avviamento 28V-3,2KW	<i>Starter engine 28V-3,2KW</i>	2.9619.120.0	FIN1865TL
17	Pompante	<i>Injection plunger</i>	0.009.4340.1	FIN1699E
18	Pompante	<i>Injection plunger</i>	2.4619.030.1	FIN1695E
19	Valvolina mandata	<i>Delivery valve</i>	2.4619.010.2	FIN1690DV
20				
21				
22				
23				
24				
25				
26				
27				
28				
29				
30				
31				
32				
33				
34				
35				
36				
37				
38				
39				
40				
41				
42				
43				
44				
45				
46				
47				
48				
49				
50				
51				
52				
53				
54				

Ricambi non originali per motori. Denominazioni e codici originali, sono riportati a puro titolo di riferimento.

36a- 68

rel. 905

Non original engine parts. OEMs names and part numbers are for reference purpose only.





SAME





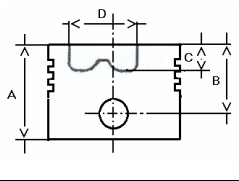

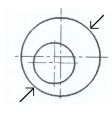
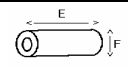

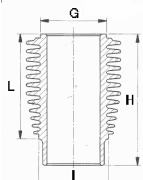
1000.6 AT	Cm ³	CILINDRI CYLINDERS	ALESAGGIO BORE	CORSA STROKE	VERSIONE VERSION
	6000	6	105	115,5	4773 → 4847

55				
56				
57				
58				
59				
60				
61				
62				
63				
64				
65				
66				
67				
68				
69				
70				
71				
72				
73				
74				
75				
76				
77				
78				
79				
80				
81				
82				
83				
84				
85				
86				
87				
88				
89				
90				
91				
92				
93				

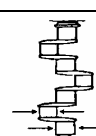
SAME

1000.6 AT	Cm³	CILINDRI CYLINDERS	ALESAGGIO BORE	CORSA STROKE	VERSIONE VERSION
	6000	6	105	115,5	4848 →

		TESTA HEAD	H47		6	3	TIPO TYPE	A	
					4	2,5			
	FIN419PN 0.078.1236.0/10		E 86 F 35		23	4		G	115,5
					105	0.381.0060.6		FIN3102PC00	0.338.0052.6/10
	105,5		FIN3102PC05	0.338.0053.6/10	FIN2320RS05	I	113		
	106				FIN2320RS10	L	125,5		
							0.007.0762.0/40 ≡ 0.007.0762.0/50	FIN1991SL00	

		Nr.						ADATTABILE A: SUITABLE FOR:	
---	---	------------	---	---	---	---	---	--------------------------------	---

CR	RP	6	63,50	67,22	29,00		STD - 025 - 050 075 - 100	0.065.1225.0 + 0.065.1225.0	FIN478CR STD
----	----	---	-------	-------	-------	--	------------------------------	--------------------------------	--------------

MB	RP	7	70,00	74,02	26,25		STD - 025 - 050 075 - 100	0.065.1215.0 + 0.065.1216.0	FIN279MB STD
----	----	---	-------	-------	-------	--	------------------------------	--------------------------------	--------------





--	--	--	--	--	--	--	--	--	--



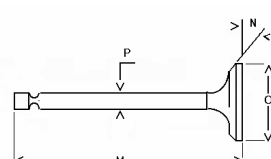

--	--	--	--	--	--	--	--	--	--

PB	BM	6	35,00	39,02	34,65		SEMIF.	2.1559.114.0/10	FIN110PB
----	----	---	-------	-------	-------	--	--------	-----------------	----------

TWS	AL	2	82,25	100,00	2,36		STD - 010 - 020	0.065.1218.0 + 0.065.1218.0	FIN167TWS STD
-----	----	---	-------	--------	------	--	-----------------	--------------------------------	---------------

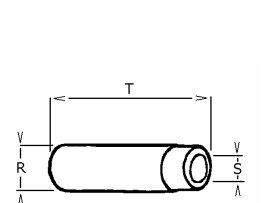
--	--	--	--	--	--	--	--	--	--

	IN EX		Nr.	O	P	M	N		ADATTABILE A: SUITABLE FOR:								
	IN								FR	6	44	9	131	30°	A1	0.010.6017.0	FINA6041
	EX								FSN	6	39,5	9	130,5	45°	A1	0.010.6022.0	FINS6042

	IN EX		Nr.	R	S	T		ADATTABILE A: SUITABLE FOR:							
	IN							G	6	15,03	9,02	60	I	0.007.1779.0/10	FIN6519ASA
	EX							G	6	15,03	9,02	60	I	0.007.1779.0/10	FIN6519ASA
	EX														

Ricambi non originali per motori. Denominazioni e codici originali, sono riportati a puro titolo di riferimento.





37 - 68





rel. 905



Non original engine parts. OEMs names and part numbers are for reference purpose only.







SAME







1000.6 AT	Cm³	CILINDRI CYLINDERS	ALESAGGIO BORE	CORSA STROKE	VERSIONE VERSION
	6000	6	105	115,5	4848 →

		 0,5 mm	
0.336.0050.6/10		0.085.1450.0	0.085.0057.6
FIN7507CGA	FIN7507CGB	FIN6281HG	FIN3104SM

		 IN	 EX
0.007.0849.0/10	0.009.3877.0/10		
FIN5005CO	FIN3211CB		

Nr.	ENGINE KIT	
1		FIN1991SL00
1		FIN3102PC00
1		FIN3104SM
0.381.0065.A/B		FIN8226KIT

 LV	 LD					
2.1529.073.0	2.1529.141.0	0.87335.51.0		0.010.3283.1	2.4419.340.0	2.4319.130.1
FIN2888RT	FIN2889RT	FIN8035AF		FIN8124NF	FIN8230OF	FIN8722FE

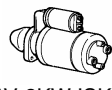
					 14V-35A	 14V-3KW ISKRA
2.4519.310.0		0.009.4303.1	2.4729.170.0/10	0.010.2630.0	2.9439.220.0/10	2.9619.180.0/10
FIN922FP		FIN1701E	FIN1725NO	FIN1698DV	FIN2288VA	FIN201TL

1	Guarnizione testa 0,7 mm	Head Gaket 0,7 mm	0.085.1451.0	FIN6282HG
2	Guarnizione testa 0,8 mm	Head Gaket 0,8 mm	0.085.1453.0	FIN6283HG
3	Guarnizione testa 1,0 mm	Head Gaket 1,0 mm	0.085.1452.0	FIN6284HG
4	OR per canna (117,07X3,53)	Liner O ring (117,07X3,53)	2.1539.130.0/10	FIN1098OR
5	Pompa olio	Oil pump	0.010.0194.4/20	FIN048OP
6	Kit revisione pompa alimentazione	Fuel pump repairing kit	2.4519.269.0	FIN2919KFP
7	Filtro Aria 8"	Air cleaner 8"	2.4249.130.0/10	FIN8244AF
8	Filtro Aria 10"	Air cleaner 10"	2.4249.380.0	FIN8263AF
9	Filtro Aria (bagno olio)	Air cleaner (oil bath)	0.88352.50.3	FIN8271AF
10	Filtro Aria (bagno olio)	Air cleaner (oil bath)	0.88353.50.3	FIN8272AF
11	Massa filtrante 10"	Filtering element 10"	2.4249.380.1	FIN8266NF
12	Massa filtrante 10"	Filtering element 10"	2.4249.380.2	FIN8267NF
13	Alternatore 14V-65A-ISKRA	Alternator 14V-65A-ISKRA	2.9439.420.0/10	FIN2320VA
14	Alternatore	Alternator	2.9439.460.0/10	FIN2330VA
15	Alternatore 26V-35A	Alternator 26V-35A	2.9439.260.0/10	FIN2305VA

Ricambi non originali per motori. Denominazioni e codici originali, sono riportati a puro titolo di riferimento.

38 - 68

rel. 905

Non original engine parts. OEMs names and part numbers are for reference purpose only.

SAME

1000.6 AT	Cm³	CILINDRI CYLINDERS	ALESAGGIO BORE	CORSA STROKE	VERSIONE VERSION
	6000	6	105	115,5	4848 →

16	Motorino d'avviamento 28V-3,2KW	<i>Starter engine 28V-3,2KW</i>	2.9619.120.0	FIN1865TL
17	Pompante	<i>Injection plunger</i>	0.009.4340.1	FIN1699E
18	Pompante	<i>Injection plunger</i>	2.4619.030.1	FIN1695E
19	Valvolina mandata	<i>Delivery valve</i>	2.4619.010.2	FIN1690DV
20				
21				
22				
23				
24				
25				
26				
27				
28				
29				
30				
31				
32				
33				
34				
35				
36				
37				
38				
39				
40				
41				
42				
43				
44				
45				
46				
47				
48				
49				
50				
51				
52				
53				
54				

Ricambi non originali per motori. Denominazioni e codici originali, sono riportati a puro titolo di riferimento.

38a- 68

rel. 905

Non original engine parts. OEMs names and part numbers are for reference purpose only.

SAME

1000.6 AT	Cm ³	CILINDRI CYLINDERS	ALESAGGIO BORE	CORSA STROKE	VERSIONE VERSION
	6000	6	105	115,5	4848 →

55				
56				
57				
58				
59				
60				
61				
62				
63				
64				
65				
66				
67				
68				
69				
70				
71				
72				
73				
74				
75				
76				
77				
78				
79				
80				
81				
82				
83				
84				
85				
86				
87				
88				
89				
90				
91				
92				
93				

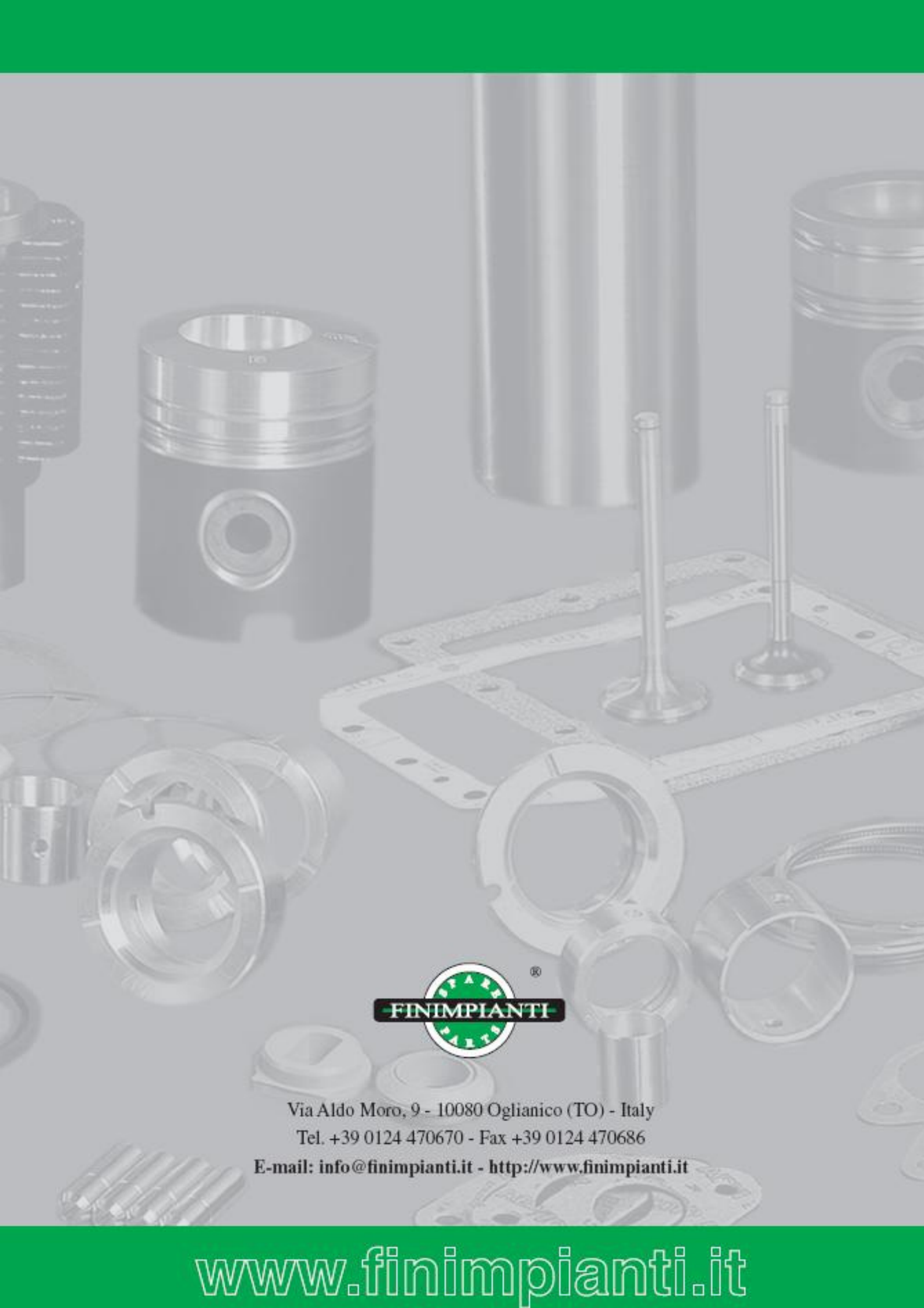

Via Aldo Moro, 9 - 10080 Oglianico (TO) - Italy

Tel. +39 0124 470670 - Fax +39 0124 470686

E-mail: info@finimpianti.it - <http://www.finimpianti.it>

www.finimpianti.it